



Food and Agriculture  
Organization of the  
United Nations



# Soil testing methods

Global Soil Doctors Programme  
A farmer-to-farmer training programme



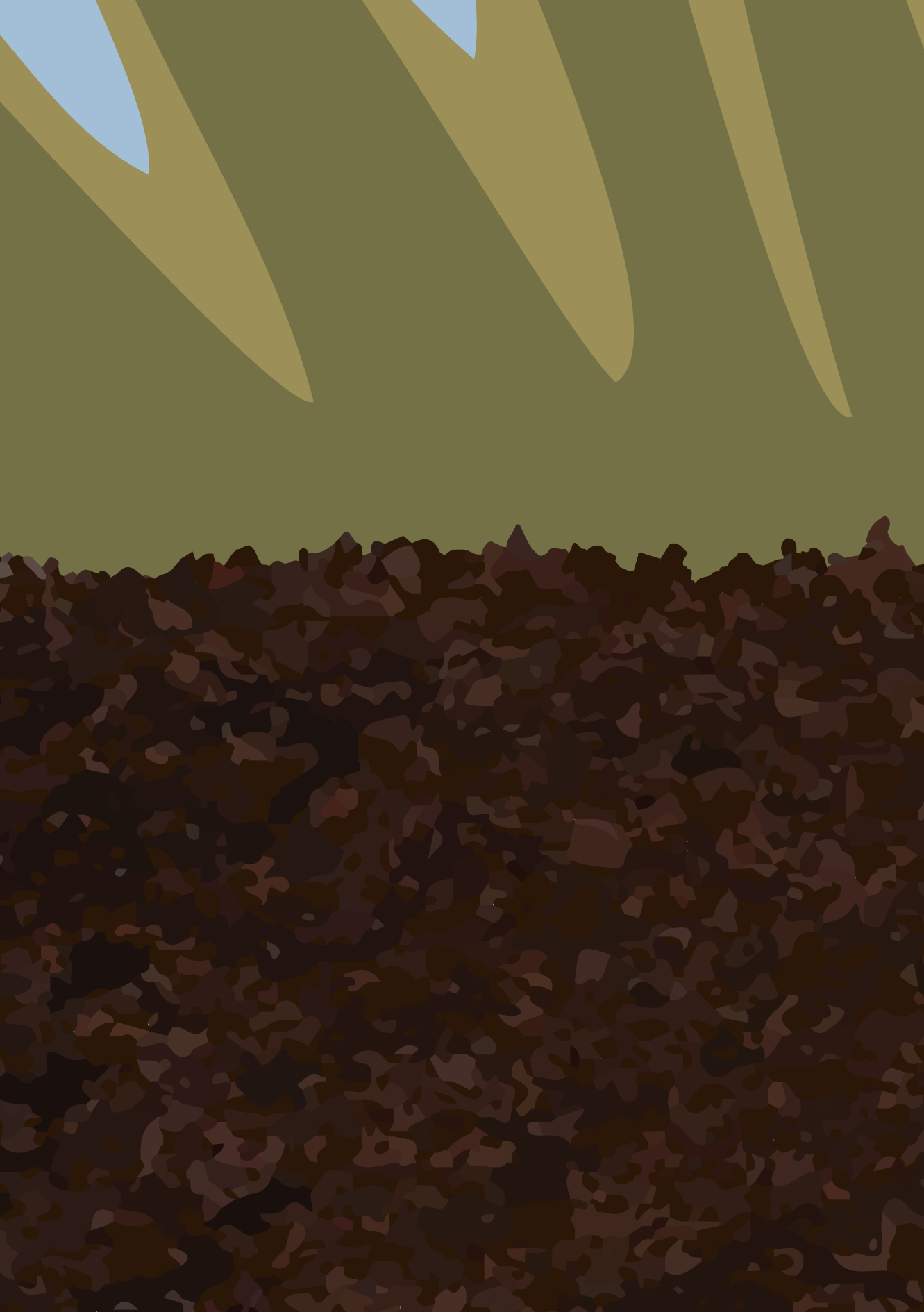

# Soil testing methods

Global Soil Doctors Programme  
A farmer-to-farmer training programme

## Required citation:

FAO. 2020. *Soil testing methods – Global Soil Doctors Programme – A farmer-to-farmer training programme*. Rome. <https://doi.org/10.4060/ca2796en>

The designations employed and the presentation of material in this information product do not imply the expression of any opinion whatsoever on the part of the Food and Agriculture Organization of the United Nations (FAO) concerning the legal or development status of any country, territory, city or area or of its authorities, or concerning the delimitation of its frontiers or boundaries. The mention of specific companies or products of manufacturers, whether or not these have been patented, does not imply that these have been endorsed or recommended by FAO in preference to others of a similar nature that are not mentioned.

The views expressed in this information product are those of the author(s) and do not necessarily reflect the views or policies of FAO.

ISBN 978-92-5-131195-0

© FAO, 2020



Some rights reserved. This work is made available under the Creative Commons Attribution-NonCommercial-ShareAlike 3.0 IGO licence (CC BY-NC-SA 3.0 IGO; <https://creativecommons.org/licenses/by-nc-sa/3.0/igo/legalcode/legalcode>).

Under the terms of this licence, this work may be copied, redistributed and adapted for non-commercial purposes, provided that the work is appropriately cited. In any use of this work, there should be no suggestion that FAO endorses any specific organization, products or services. The use of the FAO logo is not permitted. If the work is adapted, then it must be licensed under the same or equivalent Creative Commons licence. If a translation of this work is created, it must include the following disclaimer along with the required citation: "This translation was not created by the Food and Agriculture Organization of the United Nations (FAO). FAO is not responsible for the content or accuracy of this translation. The original [Language] edition shall be the authoritative edition.

Disputes arising under the licence that cannot be settled amicably will be resolved by mediation and arbitration as described in Article 8 of the licence except as otherwise provided herein. The applicable mediation rules will be the mediation rules of the World Intellectual Property Organization <http://www.wipo.int/amc/en/mediation/rules> and any arbitration will be conducted in accordance with the Arbitration Rules of the United Nations Commission on International Trade Law (UNCITRAL).

Third-party materials. Users wishing to reuse material from this work that is attributed to a third party, such as tables, figures or images, are responsible for determining whether permission is needed for that reuse and for obtaining permission from the copyright holder. The risk of claims resulting from infringement of any third-party-owned component in the work rests solely with the user.

Sales, rights and licensing. FAO information products are available on the FAO website ([www.fao.org/publications](http://www.fao.org/publications)) and can be purchased through [publications-sales@fao.org](mailto:publications-sales@fao.org). Requests for commercial use should be submitted via: [www.fao.org/contact-us/licence-request](http://www.fao.org/contact-us/licence-request). Queries regarding rights and licensing should be submitted to: [copyright@fao.org](mailto:copyright@fao.org).

# Content

<b>Introduction</b>	<b>1</b>
Introduction to rapid soil testing kits	2
<b>Soil physical properties</b>	<b>4</b>
Soil texture	4
Method 1: Feel method	6
Method 2: The ribbon method	10
Method 4: The shaking test (to differentiate clay from silt)	12
Bulk density	16
Method 1: Core method	17
Method 2: Excavation method	20
Method 3: Clod method	22
Soil moisture	24
Method 1: Gravimetric water content	25
Method 2: Volumetric water content	26
Method 3: Feel and appearance method	27
Method 4: Soil moisture determination by tensiometer	33
<b>Soil chemical properties</b>	<b>35</b>
Soil pH	35
Method 1: Soil pH meter method	36
Method 2: Color cards methods	38
Method 3: Soil pH test strip	40
Method 4: Vinegar and baking soda test	41
Soil salinity	43
Method 1: Electrical conductivity	44
Method 2: Electrical conductivity using a saturated paste	46
Method 3: Electrical conductivity using the 1:1 ratio method	47
Method 4: Presence of sulphates and chlorides	49
Method 5: Field symptoms (visual symptoms of soil salinity)	50

Soil biological properties	52
Method 1: Earthworm density	53
Method 2: Litter decomposition (tea bag method)	55
Method 3: Active/labile carbon	57
Method 4: Soil respiration – soda lime	59
Annex I: Visual soil assessments	64
2. Soil structure and consistency	70
3. Soil porosity	72
4. Soil color	74
5. Number and color of mottles	76
6. Earthworms	78
7. Potential rooting depth	80
9. Surface crusting and surface cover	84
10. Soil erosion	86
Annex II - How to use a microwave oven to dry your soil sample?	88
References	90

# Introduction

This collection of soil testing methods is part of a global farmer-to-farmer training initiative, which aims to increase the knowledge of farmers across the world on soils through trainings. This document contains a list of soil testing methods that can help the farmers in this programme assess the condition of their soil directly in the field as a way to halt soil degradation and as a first step to sustainable soil management.

Indeed, as a way to prevent soil degradation and the loss or reduction of soil functions, including the provision of healthy and nutritious food, there is an urgent need for soils to be sustainably managed. A prerequisite for the sustainable management of soil resources is the availability of reliable information and in particular, of information on how different soil management practices impact soils.

In order to provide Soil Doctors and farmers in their network with (at least) preliminary soil data, this Soil Testing Methods collection (STM) was developed as a list of methods and the necessary equipment to assess the parameters considered critical to soil health. It also includes a section on visual observations using Visual Soil Assessments (VSA) for annual crops and the information that these can provide on the health of a soil.

Ultimately, the STM is part of the Soil Doctors toolkit developed by the Global Soil Doctors programme. The training material and the Soil Testing Kit are living tools that will change and improve as we receive feedback from promoters and other users of the programme. The GSP Secretariat will therefore follow up on the use of the Soil Doctors programme material in the field for improvement.

The selection of the methods to use for assessing different soil parameters is based on the use of a comparative table like the one reported in Table 1. Each method is evaluated using the major factors that could potentially limit its use and distribution in the country. This evaluation system is based on the use of stars as described in the legend, which allows users to select the method(s) that better suit their needs. As mentioned above, the GSP Secretariat highly encourages programme users to share any feedback on the training material, including the accuracy of the evaluation tables after performing the methods in the field.

**TABLE 1. EVALUATION SYSTEM FOR THE METHODS/ EQUIPMENT EVALUATED AS FOLLOWS: FIELD SUITABILITY (\*) LOW. (\*\*) MEDIUM. (\*\*\*) HIGH.**

Method	Low cost	Low technology	High accuracy	Low difficulty	Low need for training	Low maintenance or need to replace components	Less time consuming
Method 1							
Method 2							
Method 3							
Method 4							
Etc.							

In order to provide the users with a complete and up to date list of methods and equipment, the Soil Testing Methods document is subjected to regular reviews.

The comparative advantages of promoting the use of soil testing kits among farmers in the programme are:

- To preserve and improve soil health, which is essential to achieve national food security;
- To make immediate soil management decisions on the field;
- To reduce the workload of national extension services and soil laboratories.

# Introduction to rapid soil testing kits

## *Rapid soil analyses vs laboratory methods*

Soil testing is a key tool in sustainable soil management, including judicious fertilization. The analytical works in a soil testing laboratory mainly involve standard chemical methods suitably modified to permit the handling of a large number of soil samples with the required degree of accuracy and speed. Many analytical operations are carried out more conveniently with the help of common as well as more sophisticated instruments. This mode of soil testing in laboratory usually takes from few days to weeks and the farmers often have to travel long distances to access soil testing laboratories. In some countries, there can be limited laboratory capacities with delays in obtaining the results, the number of staff that can conduct soil tests or the amount and availability of equipment, which can lead to issues with the time needed to obtain results. Rapid soil testing kits are similar to a preliminary diagnosis in medicine. The unavailability of soil testing equipment or laboratories as well as of trained individuals is the reason why rapid and on the ground soil testing are needed. To assess the ground situation in large tracts of the field/plots, it is pertinent to generate more information about the status of soils as early as possible.

Rapid soil testing kits were developed to simplify the analysis of soil physical, chemical and biological parameters in the field, which are critical to the assessment of soil health. Kits were therefore designed for on-farm testing in order to be able to make reasonable management decisions based on the results. These kits generally involve qualitative methods of analysis (e.g. dye indicators, color development and rapid titration) differentiating them from instrumental methods of analysis, which are quantitative in nature. After performing soil extractions to obtain a solute, the latter is mixed with the reagents mentioned above, which results in the solute turning into a certain color. The color can then be matched to the color chart and relevant explanation linked to the color provided in the kit. Although these tests do not provide exact values, these methods can be satisfactory for a general assessment of the soil conditions in the field.

As part of the Soil Doctors Toolkit, a Soil Testing Kit (STK) is available and can help users perform some of the methods listed in this document. This Soil Testing Kit contains some equipment that are commonly used to take a deeper look at soils in the field, such as a trowel and a tape measure, as well as a chemical kit that focuses on the aspect of soil fertility. The latter is defined as the ability of a soil to sustain plant growth by providing essential plant nutrients and favorable chemical, physical and biological characteristics



as a habitat for plant growth. The available kits can easily help users assess their soil nutrient content (N,P, K) and pH. Whenever possible, it is recommended to collect the samples and take any measurements/ perform any experiments in a temporary field office.

### Soil parameters

Soil health is defined by the Global Soil Partnership (GSP) and its Intergovernmental Technical Panel on Soils (ITPS) the capability of the soil to sustain the productivity, diversity, and environmental services of the terrestrial ecosystems. In the agroecosystems, soil health can be maintained, promoted or recovered through the implementation of sustainable soil management practices. It is an assessment of how a soil performs all of its functions, which varies depending on inputs and soil management practices, and how these soil functions can be preserved. Because soil health is not something that can be measured directly, we need indicators that are easily measured, sensitive to changes in soil functioning and covering soil physical, chemical and biological properties. In this document, a set of soil physical, chemical and biological soil properties are used as parameters to assess soil health. The latter are relatively easy to measure in the field. The methods and instructions for measuring soil nutrient content (NPK) can be found in the soil testing kit. (Doran *et al.*, 2002)

After a short introduction to the importance of each of the above-mentioned soil properties, recommended methods for their assessment are presented, together with potential advantages, disadvantages and suitability in terms of climate, crops and soil type.



# Soil physical properties

## Soil texture

The way a soil “feels” is called soil texture and represents the percentage or relative proportion of sand, silt and clay present in a soil (FAO, 2006). Sand, silt, and clay are names that describe the size of individual particles in the soil. Soil texture is fundamental to soil properties and their impact on plant growth and overall farm productivity, see Table 2. Texture is a parameter that influences soil behavior in many ways, being an important factor in water retention and availability, soil structure, aeration, drainage, soil workability and trafficability, soil biodiversity, and the supply and retention of nutrients. It is for this reason that measuring soil texture is of great importance in agricultural production. You can also visit annex I for a visual assessment of soil texture in the field.

TABLE 2 | SOIL PROPERTIES ASSOCIATED WITH SOIL TEXTURE

S/N	Property/Behavior	Rating associated with soil particles		
		Sand	Silt	Clay
1	Water holding capacity	Low	Medium	High
2	Aeration	Good	Medium	Poor
3	Drainage/infiltration rate	High	Medium	Very slow
4	Decomposition rate of Soil Organic matter	Rapid	Medium	Slow
5	Compactibility	Low	Medium	High
6	Susceptibility to wind erosion	Moderate	High	Low
7	Susceptibility to water erosion	Low	High	Low
8	Swell –shrink potential	Very low	Low	Moderate to very high
9	Sealing of ponds, dams, landfills	Poor	Poor	Good
10	Suitability for tillage after rain	Good	Medium	Poor
11	Pollutant leaching potential	High	Medium	Low
12	Ability to store plant nutrients	Poor	Medium	High
13	Resistance to pH change	Low	Medium	High
14	Warm up in winter	Rapid	moderate	Slow
15	Soil organic matter level	Low	Medium	High

Proposed methods to assess soil texture in the field are reported in Table 3



# Method 1: Feel method

## *Description:*

### Soil textural classes

The names of the textural classes, describing combined particle-size classes, are further described and coded in figure 2. In addition to the textural class, a field estimate of the percentage of clay is given. This estimate is useful for indicating increases or decreases in clay content within textural classes, and for comparing field estimates with analytical results. The relationship between the basic textural classes and the percentages of clay, silt and sand is indicated in a triangular form in figure 1.

### Subdivision of the sand fraction

Sands, loamy sands and sandy loams are subdivided according to the proportions of very coarse to coarse, medium, fine and very fine sands in the sand fraction. The proportions are calculated from the particle-size distribution, taking the total of the sand fraction as being 100 percent (Figure 1).

### Field estimation of textural classes

The textural class can be estimated in the field by simple field tests and feeling the constituents of the soil (Table 1). For this, the soil sample must be in a moist to weak wet state. Gravel and other constituents > 2 mm must be removed.

Notes	



**TABLE 4 | KEY TO SOIL TEXTURAL CLASSES - THE FEEL METHOD**

			~% clay
1 Not possible to roll a wire of about 7 mm in diameter (about the diameter of a pencil)			
1.1 Not dirty, not floury, no fine material in the finger rills:	Sand	S	< 5
If grain sizes are mixed:	Unsorted sand	US	< 5
If most grains are very coarse (>0.6mm):	Very coarse and coarse sand	CS	< 5
If most grains are of medium size (0.2-0.6 mm):	Medium sand	MS	< 5
If most grains are of fine size (<0.2 mm) but still grainy:	Fine sand	FS	< 5
If most grains are of very fine size (<0.12 mm), tending to be floury:	Very fine sand	VFS	< 5
1.2 Not floury, grainy, scarcely fine material in the finger rills, weakly shapeable, adheres slightly to the fingers:	Loamy sand	LS	< 12
1.3 Similar to 1.2 but moderately floury:	Sandy sand	SL (clay-poor)	< 10
2 Possible to roll a wire of about 3-7 mm in diameter (about half the diameter of a pencil) but breaks when trying to form the wire to a ring of about 2-3 cm in diameter, moderately cohesive, adheres to the fingers			
2.1 Very floury and not cohesive			
Some grains to feel	Silt loam	SiL (clay poor)	
No grains to feel:	Silt	Si	
2.2 Moderately cohesive, adheres to the fingers, has a rough and ripped surface after squeezing between fingers and			
Very grainy and not sticky:	Sandy loam	SL (clay-rich)	
Moderate sand grains:	Loam	L	
Not grainy but distinctly floury and somewhat sticky:	Silt loam	SiL (clay-rich)	
2.3 Rough and moderate shiny surface after squeezing between fingers and is sticky and grainy to very grainy:	Sandy clay loam	SCL	
3 Possible to roll a wire of about 3 mm in diameter (less than half the diameter of a pencil) and to form the wire to a ring of about 2-3 cm in diameter, cohesive, sticky, gnashes between teeth, has a moderately shiny to shiny surface after squeezing between fingers			
3.1 Very grainy:	Sandy clay	SC	35-55
3.2 Some grains to see and to feel, gnashes between teeth			
Moderate plasticity, moderately shiny surfaces:	Clay loam	CL	25-40
High plasticity, shiny surfaces:	Clay	C	40-60
3.3 No grains to see and to feel, does not gnash between teeth			
Low plasticity:	Silt clay loam	SiCL	25-40
High plasticity, moderately shiny surfaces:	Silty clay	SiC	40-60
High plasticity, shiny surfaces:	Heavy clay	HC	>60

NOTE: FIELD TEXTURE DETERMINATION MAY DEPEND ON CLAY MINERALOGICAL COMPOSITION. THIS KEY CAN BE USED MAINLY FOR SOILS THAT CONTAIN ILLITE, CHLORITE AND/OR VERMICULITE IN THEIR COMPOSITION. CLAYS CONTAINING SMECTITE ARE MORE PLASTIC AND THEIR CONTENT CAN BE OVERESTIMATED USING THIS KEY, AND THOSE CONTAINING KAOLINITE ARE STICKIER, AND THEIR CONTENT CAN BE UNDERESTIMATED. SOURCE: ADAPTED FROM FAO'S GUIDELINES FOR SOIL DESCRIPTION, 2006.

---

**Advantages:**

Easy to use if the key for soil texture is followed.

**Disadvantages:**

The exact percentages of sand, silt and clay are not obtained using this method.

Requires training.

**Suitability: (climate, crops, soil types)**

This method can be used in all climates and soil types.

Notes	

## Method 2: The ribbon method

### Description:

The ribbon method is closely related to the feel method as it focuses on handling the soil to determine its textural class. This easy to use method can help users determine soil texture by forming ribbons with moist soil.

### Procedure:

- **Step 1:** Take a handful of soil, around 25 grams, wet the soil and start mixing the two under the soil feels moldable. If too wet, add some dry soil and if too dry, add some more water.
- **Step 2:** Try forming a ball with the moldable soil. Can the soil form a ball? If not? Sand

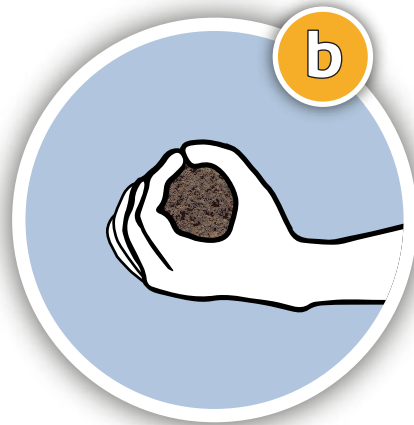

- **Step 3:** Try forming a ribbon by placing the soil between your thumb and index finger and squeezing the soil upwards to form a ribbon. Can the soil form a ribbon? If not? Loamy sand

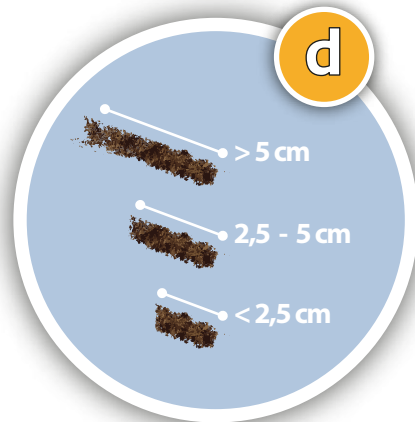



- **Step 4:** The soil can form ribbons, but how long can they get? If the ribbon breaks at 2.5 centimetres or below, the soil is a type of loam. If the ribbon is between 2.5 and 5 centimetres, it is a type of clay loam, and if it reaches over 5 centimetres, it is a type of clay.
- **Step 5:** For this step, take some of the soil, wet it, handle at the palm of your hand, and determine whether the soil feels gritty, smooth or neither gritty nor smooth. This will help you determine the textural class of your soil.



### *Types of loam*

Does the soil feel gritty? > Sandy loam

Does the soil feel smooth? > Silt loam

Neither gritty nor smooth? > Loam

### *Type of clay loam*

Does the soil feel gritty? > Sandy clay loam

Does the soil feel smooth? > Silty clay loam

Neither gritty nor smooth? > Clay loam

### *Type of clay*

Does the soil feel gritty? > Sandy clay

Does the soil feel smooth? > Silty clay

Neither gritty nor smooth? > Clay

### *Advantages*

Easy to use if instructions are followed correctly.

### *Disadvantages*

Might require some training on handling soil and forming ribbons.

### *Suitability*

This method can be used in all climates and soil types.

## Method 4: The shaking test (to differentiate clay from silt)

### Description:

This testing method can be used to differentiate between clay and silt. Both silt and clay have a smooth texture and it can be hard to tell the difference between the two even though this difference can be crucial as the two behave differently.

### Procedure:

- Take a soil sample and wet it



- Form a patty as pictured below, that is around 8cm in diameter and 1.5 cm thick.

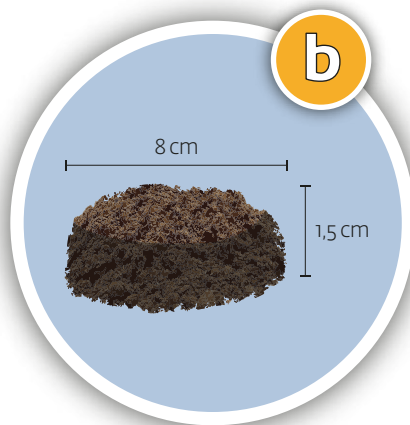

- Place the newly formed patty in your hand.
- The patty is now dull and does not have any water glistening at the surface.
- Shake the patty on the palm of your hand from side to side while looking at its surface.



- If the surface becomes shiny, then your soil is majoritararily composed of silt.
- If the surface stays dull, then your soil is mostly clayey.
- Confirm by bending the soil sample using your fingers, if it becomes dull again, it is silt.



## Soil physical properties

- Let the patty dry completely



- If it is brittle and dust comes off when rubbing your fingers on it, it is silt



- If it is firm with no dust coming off when rubbing your fingers on it, it is clay





# Bulk density

## What it is and why it is important:

Soil bulk density is an indicator of soil compaction. It is the weight of a dry soil per unit of soil volume and is usually expressed in  $\text{g/cm}^3$ . The total volume of surface soil is about 50% solids, mostly soil mineral particles (45%) and organic matter (~ 5%). The 50% left is the pore space, which is usually filled by both water and air. As an indicator of soil compaction, soil bulk density can affect the rate at which water infiltrates into the soil, the proliferation of plants roots, soil porosity, available water capacity, soil aeration and soil microbial activity. Soil bulk density changes depending on soil texture, soil structure and organic matter content. The range of soil bulk density, which is thought to not affect soil processes and plant growth is between over 1 to  $1.6 \text{ g/cm}^3$ .

The ideal soil bulk density is a function of soil health and can be improved by soil management. The management practices that improve soil organic matter are that can prevent a soil from compacting lower its bulk density. Proposed methods to assess soil bulk density in the field are reported in Table 5.

Bulk density refers normally to that of the soil without coarse fragments, which is the volume of soil that may be explored by roots, is porous and retains water. Therefore, for an accurate analysis, coarse fragments should be removed from the extracted sample, and their weight and volume subtracted from the soil's dry weight and soil bulk volume before making any calculations. Nevertheless, the coarse fragments must be taken into account (bulk density with stones) when the bulk density is used to extrapolate the results of soil analysis to surface units (e.g.. irrigation water per hectare; fertilizer needed). Therefore, you should always indicate if your bulk density is measured with or without coarse fragments.

TABLE 5. METHODS TO ASSESS BULK DENSITY IN THE FIELD

Method	Low cost	Low technology	High accuracy	Low difficulty	Low need for training	Low maintenance or need to replace components	Less time consuming
The core method	**	**	**	**	**	**	*
The excavation method	*	**	**	**	**	***	**
The clod method	*	**	**	*	*	*	**

EVALUATION SYSTEM FOR THE METHODS/ EQUIPMENT EVALUATED AS FOLLOWS: FIELD SUITABILITY (\*), LOW. (\*\*), MEDIUM. (\*\*\*) HIGH.

# Method 1: Core method

## *Description:*

This method uses a metal core of a known volume, which represents the volume of the soil for the purpose of the calculation of the soil bulk density. The core should be of cylindrical shape to allow for easy determination of its volume. The core sample is pushed into the soil to the desired depth and then gently removed without altering the contents of the core. After obtaining the soil using the core, the soil weight is measured, and using the known volume of the core (an estimation of soil volume), soil bulk density can be determined.

## *Materials needed*

- 7 – 10 cm diameter ring (the height should be the same or it could be different)
- Hand sledge/hammer
- Wooden block
- Garden Trowel
- Flat-bladed knife
- Sealable paper bags and marker pen for labeling
- Scale
- An oven (or microwave oven if not available, see the method on using a microwave oven to dry soils in the annex).

## *Procedure:*

- On the field, identify the sampling point. Try as much as possible to avoid sampling on the trail marks as they tend to be compacted or close to plant roots. Then remove some loose soil on the surface and some plant debris or some crop residues
- Then insert the ring into the soil:
  - Place the ring on the soil surface where the sample is to be taken
  - Place the wooden block on top of the metal ring to evenly drive the metal ring into the soil
  - Using the hand sledge/hammer drive the ring into the soil to a depth of 7 cm
- If the metal ring is not fully pushed into the soil, the exact depth of the ring must be determined for accurate measurements of soil volume. To do this, the height of the ring above the soil should be measured. Then subtract the height of the ring above the soil from the overall height of the ring.
- Remove the ring from the soil:
  - Using the hand trowel, dig around the ring, reach underneath the ring with the trowel and carefully lift it out while trying to prevent any soil loss from the ring

## Soil physical properties

- Remove excess soil:
  - Using the flat-bladed knife, remove the excess soil from the ring. The bottom and upper part of the soil sample within the ring should be flat and even with the edges of the ring
- Place the sample in the bag and label it
  - Using the flat-bladed knife, push the soil sample from within the metal ring into the sealable paper bag. Be careful while transferring the sample and make sure that the entire sample is placed into the bag. Properly seal it and label accordingly.
- Weigh and record the sample:
  - Weigh the field moist soil sample and its bag and separately weigh the sampling bag without a soil sample. To get the actual weight of the soil sample, subtract the weight of the sampling bag from the weight of the sample together with the bag. This difference is the weight of the soil (wet weight =  $W_t$ ).
- Dry the sample
  - Place the samples in the paper bag into the oven dryer
  - Let the samples dry for about 24 hours at 105 degrees Celsius or at 40 degrees Celsius for several days (until dry) when dealing with soils high in gypsum.
  - After drying, weigh the dry sample (soil + sampling bag). Then subtract the weight of the sampling bag from the sample (dried soil + sampling bag). This is the weight of dry soil without the sampling bag ( $W_d$ ).
- **Calculate the soil's bulk density**

- $$\rho = \left( \frac{W_d}{V} \right)$$

- $$\theta_d = \left( \frac{W_t - W_d}{W_d} \right) * 100$$

- $$\theta_v = \left( \frac{\theta_d * \rho_s}{\rho_w} \right) * 100$$

- $$V = \pi r^2 * h$$

- $$SP(\%) = \left( 1 - \frac{\rho}{2.65} \right) * 100$$

- **Water saturation of the field pore space.** 
$$(\%) = \left( \frac{\theta_v}{SP} \right) * 100$$





## Method 2: Excavation method

### *Description:*

Unlike the core method, which uses a cylindrical sampler in order to determine the volume of the soil, the excavation method uses the relationship of water with its mass and volume, that is, 1 g of water equals 1 mL of water, which is derived from the fact that the density of water is 1 g/mL. This method consists of carefully digging a hole in the field and then filling water of the known volume in that hole until it is well filled to the capacity (the water level inside the hole is leveled to the soil surface). The hole is lined with an impermeable plastic to avoid water drainage into the soil. The known water volume poured in the hole will thus be equivalent to the volume of soil that had occupied that space. Then the soil mass will be determined later after the soil has been left to dry, either oven dried or to air dried.

### *Materials needed*

- A hand trowel or a shovel
- Impermeable plastic material to fill the hole
- A graduated cylinder (1000 ml – 2000 ml)
- Water ( the amount of water will depend on the number of samples to be taken)
- An oven (or microwave oven if not available, see the method on using a microwave oven to dry soils in the annex).

### *Procedure*

- With the trowel or a shovel, level the soil surface until flat where the sample is to be obtained
- Using the trowel or shovel, dig a hole in the soil to the desired depth (the shape of the hole will depend on the person doing the sampling).
- The dug soil from the hole will need to be placed into the sealable paper bag (make sure that there no soil is lost when transferring the soil from the hole to the sampling bag)
- Line the hole with a plastic bag (make sure that the plastic bag has properly covered the hole and takes the entire shape of the hole)
- Fill the hole with the known volume of water (the water volume is measured using the graduated cylinder). Based on water density, the volume of water filled into the hole is equivalent to the volume of soil that is excavated ( $V_s$ ).
- Then oven dry the excavated soil for about Gypsum issue and then weigh the oven dried soil ( $W_d$ ) or at 40 degrees Celsius for several days (until dry) when dealing with soils high in gypsum.

### *Calculations*

For calculations on bulk density and the related equations please refer to the list of equations above

### *Advantages:*

- It can be carried out on stony or gravelly soils

- If properly carried out, it can provide a more accurate estimation of soil bulk density

**Disadvantages:**

- It is quite destructive and excavated soil is no longer undisturbed
- Depending on the number of samples to be taken, it can be hard to carry water around the field

**Suitability: (climate, crops, soil types)**

- The method is suitable under most soil types and different climates.

Notes	

## Method 3: Clod method

### *Description:*

This method consists of using a clod of soil, regular or irregular. The clod is submerged into the known volume of water in a graduated container. Upon submersion into the water, the clod will occupy the space that was initially occupied by water and thus causing a change of volume inside the water container. This new volume reading is as a result of replaced water volume by the clod and thus represent the volume of the soil. It is important to prevent the water from soaking into the clod. This is achieved by coating the clod in wax, which will prevent the water from penetrating the clod and overestimating the soil's volume. Following are some of the materials needed and the procedures to follow when determining soil bulk density using this method.

### *Materials needed*

- Shovel/trowel
- Sealable sample paper bag and markers for sample labeling
- Oven dryer
- Weighing scale
- Paraffin wax and the means to melt it
- A graduated beaker and water
- Thread (~ 50 cm)
- An oven (or microwave oven if not available, see the method on using a microwave oven to dry soils in the annex).

### *Procedure*

- Using a shovel or a trowel, dig out a clod of soil from the ground.
- Carefully place it in a sealable sampling paper bag and transport it to the laboratory or any processing place.
- Carefully measure the sample (wet weight,  $W_t$ ) and then oven dry the sample for about 24 hours at 105 degrees Celsius and measure the oven dried sample (dry weight,  $W_d$ ) or at 40 degrees Celsius for several days (until dry) when dealing with soils high in gypsum.
- After drying, carefully tie a thread around the clod so that the clod could be lifted up using the thread. The distance between the suspending clod and the other end of the thread can be around 20 cm .
- Using a ceramic bowl, melt the paraffin wax at around 50 -70 degrees Celsius.
- Then dip the suspending clod in the wax, make sure that the clod is fully covered in wax. This helps to prevent the water from soaking into the clod.
- Then wait for some minutes for the wax to cool off and solidify.
- Measure the weight of the wax-coated clod ( $W_x$ ) and then subtract the dried soil weight ( $W_d$ ) from clod wax coated weight ( $W_x$ ) to get the original weight of the clod without wax ( $W_{d2}$ ).  $W_{d2}$  is the weight of the oven dry soil without the wax.



# Soil moisture

## What it is and why it is important:

Soil moisture represents the content of water within a soil. This water is held within the pore space, which is the space between soil particles. In addition to the water that is within the pore space, there is also a portion of soil water that holds onto the soil particles (colloids). This water film around soil particles is due the chemical properties of water (positive electrical charge) and the electrical charge of the soil particles (which is negative). The forces responsible for water retention on the colloids are called surface retention and surface attraction, and are collectively known as surface moisture retention. With respect to crops/plants, this refers to the amount of energy that the crops may need to obtain water for their physiological growth. Soil moisture is the major component of soil in relation to crop growth and together with soil pH, are the principal determinants of soil reactions, and heat and gaseous exchanges within the soil. Along with crops satisfying their water demand, the water contained in a soil also helps crops absorb nutrients in the form of dissolved salts.

Information on soil moisture is necessary for:

- Assessing plant water requirement and scheduling irrigation
- Plant water uptake and use
- Water storage capacity of soil
- Rate and quantity of water movement
- Determination of crop yield
- Chemical and biological activity of the soil

Proposed methods to assess soil moisture in the field are reported in Table 7.

TABLE 7. METHODS TO ASSESS SOIL MOISTURE IN THE FIELD

Method	Low cost	Low technology	High accuracy	Low difficulty	Low need for training	Low maintenance or need to replace components	Less time consuming
Gravimetric water content	**	**	***	**	**	**	**
Volumetric water content	**	**	***	**	**	***	**
Feel appearance	***	***	*	***	**	***	***
Soil Tensiometer	*	*	*	*	*	*	**

EVALUATION SYSTEM FOR THE METHODS/ EQUIPMENT EVALUATED AS FOLLOWS: FIELD SUITABILITY (\*) LOW, (\*\*) MEDIUM, (\*\*\*) HIGH.

# Method 1: Gravimetric water content

## Description:

Gravimetric water content is the mass of water per mass of dry soil. It is measured by weighing a field moist soil (wet weight) and then either drying that soil (over a period of a week) or oven drying it for about 24 hours at a temperature of 105°C to remove all water. The soil should then be weighed again (to determine the dry weight). The difference between the wet and the dry weight is the amount of water in that soil.

## Materials needed

- Soil probe or soil auger
- Sealable soil sample bags
- Weighing scale
- Oven (or microwave oven if not available, see the method on using a microwave oven to dry soils in the annex). (optional but recommended)

## Procedure

- Using the normal procedure for soil sampling, obtain a soil sample from a desired depth using a soil probe or soil auger (or even a shovel/trowel)
- Then place the soil samples in the sealable sample paper bags, label the samples and transport them to the laboratory or any soil processing facility
- Measure the weight of the field wet soil ( $W_t$ )
- Oven dry the soil for about 24 hours at 105 degrees Celsius or air dry the soil for 7 days
- After drying, weigh the soil in order to obtain the dry weight of that soil ( $W_d$ )
- Then calculate the water content of the soil

## Calculations

$$\text{Gravimetric water content} = \theta_d = \left( \frac{W_t - W_d}{W_d} \right) * 100$$

Where:  $W_t$  = Weight of field moist soil (g)

$W_d$  = Weight of dried soil (g)

## Advantages:

- The method is easy to perform and does not require much technical knowledge

## Disadvantages:

- Some equipment like oven dryers can be expensive, but the drying of the soil could be done by allowing the samples to air-dry for a period of 7 days.
- A weighing scale is needed for this method

## Suitability: (climate, crops, soil types)

- N/A

## Method 2: Volumetric water content

### Description:

Volumetric water content is similar to gravimetric water content with the only the difference being that water content on mass basis (as determined by the gravimetric method) is converted into volumetric basis using the soil's bulk density as the conversion factor. This method measures the volume of water per volume of soil. Please see the method above for more information on the gravimetric water content method.

$$\text{Volumetric water content} = \theta_v = \left( \frac{\theta d * \rho_s}{\rho_w} \right) * 100$$

**Where:**  $\theta_v$  = volumetric water content (cm<sup>3</sup> of water /cm<sup>3</sup> of soil)

$\theta d$  = gravimetric water content (g/g)

$\rho_s$  = Soil bulk density (g/cm<sup>3</sup>)

$\rho_w$  = density of water (g/cm<sup>3</sup>) = 1

### Advantages:

- Since it is derived from gravimetric water content, the method assumes the qualities of the gravimetric method.
- However, the method is highly recommendable when the results are going to be used in determining the stock of nutrients or carbon in the soil.

### Disadvantages:

- The accuracy of the results depend on the accuracy of the soil's bulk density that is used as a conversion factor.
- A weighing scale is needed for this method (see disadvantages for method 1).

### Suitability: (climate, crops, soil types)

- N/A



# Method 3: Feel and appearance method

## Description:

The feel and appearance of a soil vary depending on its texture and soil moisture content. Due to these properties, soil moisture content could be estimated through how it feels and appears when handled. With this method of soil moisture estimation, moisture is typically sampled in increments to the root depth of the crop at around three or more sites per field. To carry out this approach, it is advisable to vary the number of sample sites and depths according to crop, field size, soil texture and soil stratification.

## Procedures

- Obtain a soil sample at a selected depth using either a soil probe, an auger and/or a shovel
- After obtaining a soil sample and handling it, squeeze the soil sample firmly several times to form an irregularly shaped ball.
- Then squeeze the soil sample out of your hand between your thumb and forefinger to form a ribbon/ worm with the soil.
- With careful attention to soil texture, the ability of a soil to form a ribbon when squeezed, the firmness and surface roughness of the ball, water glistening, loose soil particles, soil color and staining on the fingers; one can then estimate the percentage of soil moisture.
- The table below (Table 8) will provide a guideline on how to estimate soil moisture using the feel and appearance method.







Notes	







**TABLE 8. GUIDELINE FOR ESTIMATING SOIL MOISTURE CONTENT BY FEEL AND APPEARANCE METHOD FOR SOILS OF DIFFERENT TEXTURE**

Available soil Moisture Percentage	Coarse Texture – Fine Sand And Loamy Fine Sand	Moderately Coarse Texture – Sandy Loam And Fine Sandy Loam	Medium Texture – Sandy Clay Loam, Loam, And Silt Loam	Fine Texture – Clay, Clay Loam, or Silty Clay Loam
0-25	Dry, loose, will hold together if not disturbed, loose sand grains on fingers with applied pressure.	Dry, forms a very weak ball, aggregated soil grains break away easily from ball.	Dry, soil aggregations break away easily. No moisture staining on fingers, clods crumble with applied pressure.	Dry, soil aggregations easily separate, clods are hard to crumble with applied pressure
25-50	Slightly moist, forms a very weak ball with well-defined finger marks, light coating of loose and aggregated sand grains remain on fingers.	Slightly moist, forms a weak ball with defined finger marks, darkened color, no water staining on fingers, grains break away	Slightly moist, forms a weak ball with rough surfaces, no water staining on fingers, few aggregated soil grains break away.	Slightly moist, forms a weak ball, very few soil aggregations break away, no water stains, clods flatten with applied pressure
50-75	Moist, forms a weak ball with loose and aggregated sand grains on fingers, darkened color, moderate water staining on fingers, will not form a ribbon.	Moist, forms a ball with defined finger marks. very light soil/water staining on fingers. darkened color, will not slick.	Moist, forms a ball, very light water staining on fingers, darkened color, pliable, forms a weak ribbon between thumb and forefinger.	Moist. forms a smooth ball with defined finger marks, light soil/water staining on fingers, ribbons between thumb and forefinger.
75-100	Wet, forms a weak ball, loose and aggregated sand grains remain on fingers, darkened color, heavy water staining on fingers, will not form a ribbon.	Wet, forms a ball with a wet outline left on hand, light to medium water staining on fingers, makes a weak ribbon between thumb and forefinger.	Wet, forms a ball with well defined finger marks, light to heavy soil/water coating on fingers, ribbons between thumb and forefinger.	Wet, forms a ball, uneven medium to heavy soil/water coating on fingers, ribbons easily formed between thumb and forefinger.
100 (Field Capacity)	Wet, forms a weak ball, moderate to heavy soil/ water coating on fingers, wet outline of soft ball remains on hand.	Wet, forms a soft ball, free water appears briefly on soil surface after squeezing or shaking, medium to heavy soil/water coating on fingers.	Wet, forms a soft ball, free water appears briefly on soil surface after squeezing or shaking, medium to heavy soil/water coating on fingers.	Wet, forms a soft ball, free water appears on soil surface after squeezing or shaking, thick soil/ water coating on fingers, slick and sticky.



**TABLE 9. PICTORIAL GUIDELINE FOR ESTIMATING SOIL MOISTURE CONTENT BY FEEL AND APPEARANCE METHOD FOR SOILS OF DIFFERENT TEXTURE**

Available soil Moisture Percentage	Coarse Texture – Fine Sand And Loamy Fine Sand	Moderately Coarse Texture – Sandy Loam And Fine Sandy Loam	
0-25	Dry, loose, will hold together if not disturbed, loose sand rains on fingers with applied pressure.	Dry, forms a very weak ball, aggregated soil grains break away easily from ball.	
25-50	Slightly moist, forms a very weak ball with well-defined finger marks, light coating of loose and aggregated sand grains remain on fingers. 	Slightly moist, forms a weak ball with defined finger marks, darkened color, no water staining on fingers, grains break away 	
50-75	Moist, forms a weak ball with loose and aggregated sand grains on fingers, darkened color, moderate water staining on fingers, will not ribbon. 	Moist, forms a ball with defined finger marks. Very light soil/water staining on fingers. Darkened color, will not slick. 	
75-100	Wet, forms a weak ball, loose and aggregated sand grains remain on fingers, darkened color, heavy water staining on fingers, will not ribbon. 	Wet, forms a ball with wet outline left on hand, light to medium water staining on fingers, makes a weak ribbon between thumb and forefinger. 	
100 (Field Capacity)	Wet, forms a weak ball, moderate to heavy soil/ water coating on fingers, wet outline of soft ball remains on hand.	Wet, forms a soft ball, free water appears briefly on soil surface after squeezing or shaking, medium to heavy soil/water coating on fingers.	

<p>Medium Texture – Sandy Clay Loam, Loam, and Silt Loam</p>	<p>Fine Texture – Clay, Clay Loam, or Silty Clay Loam</p>
<p>Dry soil aggregations break away easily. No moisture staining on fingers, clods crumble with applied pressure.</p>	<p>Dry, soil aggregations easily separate, clods are hard to crumble with applied pressure</p>
<p>Slightly moist, forms a weak ball with rough surfaces, no water staining on fingers, few aggregated soil grains break away</p> 	<p>Slightly moist, forms a weak ball, very few soil aggregations break away, no water stains, clods flatten with applied pressure</p> 
<p>Moist, forms a ball, very light water staining on fingers, darkened color, pliable, and forms a weak ribbon between thumb and forefinger.</p> 	<p>Moist. Forms a smooth ball with defined finger marks, light soil/water staining on fingers, ribbons between thumb and forefinger.</p> 
<p>Wet, forms a ball with well-defined finger marks, light to heavy soil/water coating on fingers, ribbons between thumb and forefinger.</p> 	<p>Wet, forms a ball, uneven medium to heavy soil/water coating on fingers, ribbons easily between thumb and forefinger.</p> 
<p>Wet, forms a soft ball, free water appears briefly on soil surface after squeezing or shaking, medium to heavy soil/water coating on fingers.</p>	<p>Wet, forms a soft ball, free water appears on soil surface after squeezing or shaking, thick soil/water coating on fingers, slick and sticky.</p>

## Soil physical properties

### *Advantages:*

- It is a quick field method that provides an estimate of soil moisture

### *Disadvantages:*

- Though it appears easy and quick, the method is subjective and depends on the experience of the person in making this measurement
- The method is not reliable

### *Suitability: (climate, crops, soil types)*

- N/A

Notes	

# Method 4: Soil moisture determination by tensiometer

## *Description:*

A Tensiometer is a sealed, airtight, water-filled tube with a ceramic porous tip on one end and a vacuum gauge on the other. A tensiometer is used to estimate soil moisture content by measuring soil water suction, which is normally expressed as tension. The suction is basically an equivalent of energy that a plant must exert to withdraw water from the soil. This is the water that is held onto soil particles and thus the tensiometer provides an estimate of available soil water to the plant. The suction force in the porous tip is transmitted through the water column inside the tube and displayed as a tension reading on the vacuum gauge. The units are commonly expressed as bars, centibars or kilopascal. Then these readings are converted into soil moisture content by using a monograph (soil moisture curves). For each suction, there is a corresponding soil moisture content.

## *Materials needed*

- Tensiometer (consists of several parts which are, cylindrical tube, vacuum gauge, porous ceramic cup)
- Water container
- Water

## *Tensiometer preparation*

- Always calibrate the conductivity meter according to maker's instructions.
- Dip the ceramic cup in water for about 12 hours before use.
- Insert the rubber washer into the top of the tube and then fasten the pressure gauge to the tube and close tightly
- Open the water entry tube on the side of the tube to fill water into the tube. Pour the water until the tube is fully filled with water.
- Hold the tensiometer in the air for some time until the gauge reading appears.
- Try to calibrate the tensiometer by inserting it into the water vertically for few minutes. Make sure that the porous ceramic cup is not touching the base of the water container and is submerged underwater by at least 2 cm.
- The tensiometer is now ready to be taken to the field for water content measurements.

## *Field installation and measurement*

- Select a site for installation in the field at least 10 m away from the edge of the field.
- Use something to drill the soil where you will insert the tensiometer (you can either use a soil probe or any material that can drill through the soil)
- Then install the tensiometer into the soil at root depth and ensure that the tensiometer is in close contact with its porous ceramic cup and the soil (if you have more than one tensiometer you can insert many of them to have a representative soil moisture content of the whole field).





# Soil chemical properties

## Soil pH

What it is and why it is important:

Soil pH is a measure of the amount of acidity or alkalinity (basicity) that is present in the soil. Soil pH is measured on a scale of 0 to 14, with pH level below 7 being acidic while pH level above seven being alkaline (or basic). A pH of 7 is considered neutral (neither acidic nor alkaline). Soil pH is a very important soil property due to its ability to determine the availability of nutrients for plant uptake. Different soil nutrients are available for uptake by plants at different soil pH levels. Some soil nutrients are available at acidic pH while others are available at alkaline pH levels. The Soil pH level that allows for a wider nutrient availability to crops is in the 5.5 to 7.5 range. At times, an inappropriate soil pH may appear to be a symptom of a disease or pest infection and without a proper diagnosis; this may lead to crop damage or unnecessary financial losses. A key factor for proper management of crop nutrition is therefore to measure the exact soil pH level.

Soil pH can be adjusted or corrected to a desired level for crop production..

Proposed methods to assess soil pH in the field are reported in Table 10.

TABLE 10. METHODS TO ASSESS SOIL pH IN THE FIELD

Method	Low cost	Low technology	High accuracy	Low difficulty	Low need for training	Low maintenance or need to replace components	Less time consuming
pH meter	**	**	***	**	**	*	**
Color cards	*	**	**	**	**	*	**
pH strips	**	**	**	***	***	*	***
Vinegar and Baking Soda	***	***	*	***	***	***	***

EVALUATION SYSTEM FOR THE METHODS/ EQUIPMENT EVALUATED AS FOLLOWS: FIELD SUITABILITY (\*) LOW. (\*\*) MEDIUM. (\*\*\*) HIGH.

# Method 1: Soil pH meter method

## *Description:*

This method uses an electrometric device, which consists of a glass electrode that is sensitive to hydrogen ions ( $H^+$ ) – which are used to measure the level of acidity. The glass electrode contains a salt solution (sodium based –  $Na^+$ ) and when this glass electrode is immersed into the soil solution, there is an exchange of ions between the soil solution ( $H^+$ ) and the glass ( $Na^+$ ). A reference electrode that produces a constant voltage is also required, which when immersed with the glass electrode into the soil solution produces an electromotive force (voltage) or electrical potential that is measured by a millivoltmeter. This estimates the soil's pH.

## *Materials needed*

- 50 -100 mL graduated water bottle with a cap
- A measuring scoop (a table tea-spoon)
- pH meter
- Calibration solutions (a solution of pH 4 and 7)
- Wash bottle
- Water (deionized if possible)
- Air dried soil

## *Procedure (Active soil pH)*

- Place a table tea-spoon full of air dried soil (if the measuring scale is present – measure a 20 g sample of soil) into the water bottle
- Add 40 ml of water (deionized if possible)
- With the bottle cap on, shake the soil solution vigorously by hand for a minute
- Wait 20 to 30 minutes for the solution to settle
- Always calibrate the conductivity meter according to maker's instructions
- Finally, measure the pH of the soil solution by inserting both pH electrodes into the soil solution. Make sure that the electrodes are not in direct contact with soil residues in the water bottle but rather with the supernatant solution.
- The resulting reading on the pH meter is the pH of that soil.

---

\*NB: THE TYPE OF PH THAT IS MEASURED ONLY USING WATER IS CALLED PASSIVE ACIDITY. THIS MEASURES ONLY THE ACIDITY WITHIN THE SOIL SOLUTION (SOIL WATER) WITHOUT TAKING INTO ACCOUNT THE ACIDITY AT THE EXCHANGE SITES OF THE SOIL. THIS TYPE OF ACIDITY (ON THE EXCHANGE SITES) IS CALLED THE ACTIVE ACIDITY. IT IS DETERMINED BY ADDING A KNOWN AMOUNT OF POTASSIUM CHLORIDE INTO THE SOIL SOLUTION AFTER ADDING WATER. THIS PH MEASURE SHOULD BE LOWER THAN THE ONE MEASURED ONLY USING WATER.

---



## Method 2: Color cards methods

### *Description:*

This method uses pH indicators (universal indicators). These are chemical compounds that change in color when mixed with either an acidic or an alkaline solution. In estimating soil pH, these indicators are added to a soil solution and depending on the concentration of hydrogen or hydroxide ions; the color of the soil solution will change accordingly. The corresponding color change is then compared with the already known and established pH color cards. These cards have a range of colors that represent the pH scale (from 0 – 14). Matching the color obtained from the soil solution to that of the color cards provides an estimation of the pH of that soil.

### *Materials needed*

- 50 ml graduated water bottle with a cap
- A measuring scoop (or a teaspoon)
- A universal pH indicator solution
- A pH color chart
- Water (deionized if possible)
- Air dried soil

### *Procedure*

- Place a half full teaspoon of soil in the 50 ml water bottle
- Pour 2-3 drops of universal indicator solution into the soil. When the indicator is fully mixed with the soil, it will give off a certain color (ranging from blue to orange)
- Match the color obtained with the pH color card
- The resultant match is an estimation of the soil's pH
- When using the litmus paper instead of color charts
  - Place a half full teaspoon of soil into the 50 ml bottle
  - Add about 20 ml of water to the soil (make sure the soil does not become too wet)
  - Bring into contact the litmus paper with the soil solution. The litmus paper will give off a color
  - Match the color from the litmus paper with the pH color cards
  - The resultant match is the estimation of that soil's pH

**Advantages:**

- The method is quick and could be used to estimate the pH range in the field and is relatively easy

**Disadvantages:**

- It only provides soil pH by proxy and may be a limitation if the exact pH value is needed
- The universal solution can be difficult to find and is expensive.
- There can be many factors that interfere with the pH such as high SOC content, flooded soils etc.

**Suitability: (climate, crops, soil types)**

- N/A

Notes	

## Method 3: Soil pH test strip

### *Description:*

The pH test strip method uses the same principle as the universal indicator solution with the exception that with the test strip, the indicator is not a solution but rather a piece of paper. A certain quantity of soil (2 – 3 teaspoons) is mixed with around 500mL of water (deionized if possible) and then shaken vigorously by hand for 3 to 5 minutes. The solution is left for some time to allow for the settling of soil particles. After the solution has settled, the paper strip (indicator paper) is inserted into the solution. Upon inserting the indicator paper into the solution, and depending on the pH of the solution, the color of the paper will change. The corresponding color change will then be matched to the pH color charts to estimate the pH of that soil.

### *Materials needed:*

- pH paper strips and color charts
- A graduated container (a beaker or a transparent plastic container)
- Water (Deionized water if possible)
- Measuring scoop or teaspoon

### *Procedure:*

- Add 2 teaspoons of air dried soil into a container
- Add about 500mL of deionized water into the container
- Shake the mixture for about 3-5 minutes by hand
- Let the solution settle for about 5 minutes
- After the solution has settled, insert the paper strip into the solution to observe the color change of the paper strip
- After the paper strip has gone through the color change, match the color on the paper strip to the corresponding color chart. The resultant matching will give an estimation of that soil's pH.

### *Advantages:*

- The method is quick and does not require much training
- Can quickly determine a soil's pH in the field

### *Disadvantages:*

- It only provides soil pH by proxy and may be a limitation if the exact pH value is needed

### *Suitability: (climate, crops, soil types)*

- N/A

# Method 4: Vinegar and baking soda test

## *Description:*

This method is based on the pH of both vinegar and baking soda and how the latter react with materials or chemicals with a different pH. Vinegar is acidic and when it comes into contact with an alkaline material (or chemical compound) it foams, bubbles and fizzes. Baking soda is alkaline, and when it comes into contact with an acidic material (chemical), it also foams, bubbles and fizzes. Due to the chemical properties of both vinegar and baking soda mentioned above, these compounds can be used to provide a rough estimate of soil pH in the field. If vinegar reacts to a soil, then that soil has an alkaline pH and similarly, if baking soda reacts to a soil, then that soil has an acidic pH.

This is just a quick estimation of a soil's pH, and it does not provide neither the range of soil pH nor absolute values. It just gives an idea of whether that soil is acidic, alkaline, or neutral (if no reactions occur). The results obtained using this method will therefore need to be further confirmed using methods that are more accurate.

## *Materials needed:*

- A hand trowel or shovel
- A container to hold soil (a ceramic cup or anything that can hold the soil without interfering with the reaction)
- Vinegar
- Baking soda
- Water filled container (deionized water if possible)
- Anything to stir the soil water mixture with (a spoon or even a wooden material)

## *Procedure*

- Clear off the sampling points off any vegetation or any leaf or root debris
- Using a hand trowel or shovel, obtain some soil from any other desired depth
- Look for any plant roots or debris and try to remove them from the soil sample as much as possible
- Put the soil into the cup or container
- Add some water to the soil to turn it into a soil paste (not too wet nor too dry, it should have some consistency)
- **Acidity Test:**
  - Into the already prepared soil paste, add about ½ cup of baking soda to the soil paste and stir lightly (about 1 - 2 minutes)
  - If after stirring, the soil gives off fizzing sounds, forms bubbles or foams, then that soil is acidic
- **Alkalinity Test**
  - Into the already prepared soil paste, add about ½ cup of vinegar to the soil paste and stir slightly (about 1 – 2 minutes)
  - If after stirring, the soil gives off fizzing sound, forms bubbles and or foams, then that soil is alkaline

## Soil chemical properties

### *Advantages:*

- This method is fast, easy and could be performed by any person without any technical knowledge of soils or specific equipment

### *Disadvantages:*

- The method does not provide the exact or absolute values of soil pH but an indication of whether the soil is acidic or alkaline. The results obtained will therefore still need to be validated using more accurate methods.

### *Suitability: (climate, crops, soil types)*

- N/A

Notes	



# Soil salinity

## What is it and why is it important:

Salts more soluble than gypsum can be transported to the soil surface by capillary transport from a salt laden water table and accumulate in the soil due to evaporation. Salinization occurs when irrigation practices are carried out without due attention to drainage and leaching of the salts out of the soil. Salts more soluble than gypsum can also accumulate due to seawater intrusion, or may occur naturally. As soil salinity increases, its impacts can result in degradation of soils and vegetation. The most common salts are combinations of the cations sodium, calcium, magnesium and potassium with the anions chlorine, and sulfates.

Proposed methods to assess soil salinity in the field are reported in Table 6.

TABLE 11. METHODS TO ASSESS SOIL SALINITY IN THE FIELD

Method	Low cost	Low technology	High accuracy	Low difficulty	Low need for training	Low maintenance or need to replace components	Less time consuming
Electrical conductivity	**	**	***	**	**	**	***
Saturated paste	**	**	**	**	**	**	*
1:1 ratio method	**	**	**	**	**	**	***
Presence of sulphates and chlorides	***	**	*	**	**	**	**
Field symptoms	***	***	*	**	**	***	***

EVALUATION SYSTEM FOR THE METHODS/ EQUIPMENT EVALUATED AS FOLLOWS: FIELD SUITABILITY (\*) LOW, (\*\*) MEDIUM, (\*\*\*) HIGH.

# Method 1: Electrical conductivity

## *Description:*

Electrical Conductivity (EC) is a measure of the ability of a solution to carry an electric current or the concentration of soluble salts in the sample at any specific temperature. The EC measurement is affected by dissolved  $\text{CO}_2$ , the temperature and the nature of the various ions involved, and their relative concentration. EC can be measured in the field or in the laboratory using a conductivity meter, which measures the inverse of the electrical resistance of a solution. Conductivities range from less than 0.02 dS/m for distilled water to more than 20 dS/m for highly saline waters. The following methods only involve the preparation of samples and refer back to this method (method 1).

## *Materials needed:*

- Conductivity meter
- Conductivity cell
- Pipette
- Thermometer
- A beaker

## *Procedures*

The first step involves the calibration of the conductivity meter

- *Always calibrate the conductivity meter according to maker's instructions*
- Rinse the conductivity cell thoroughly with water (deionized water if possible), and dry the excess water.
- Rinse the conductivity cell thoroughly with a measured solution a few times.
- Put about 75 mL of water sample in a 100 mL glass beaker, and then put the clean and dried conductivity cell in the glass beaker.
- Record the reading. This is the EC of the solution.
- The temperature should be 25 °C, and the result expressed in dS/m. If the measurement is done at another temperature, it should be corrected.
- Check the accuracy of the EC meter using a 0.01 N KCl solution, which should give a reading of 1.413 dS/m at 25 °C.
- The readings are recorded in mmhos/cm or dS/m.

**Advantages:**

- The reading from this method is highly accurate.

**Disadvantages:**

- A specific device for measuring electrical conductivity is needed.
- There is a high risk of contamination and therefore of wrong readings.
- A temperature of 25 °C is needed for accurate readings.
- Careful reading of instructions for the use of the apparatus are needed.

**Suitability: (climate, crops, soil types)**

- N/A

Notes	

## Method 2: Electrical conductivity using a saturated paste

### *Description:*

This method uses an extract from a saturated paste for the determination of saline soils. It is also possible to obtain soluble cations and anions by this method and estimate other important parameters such as Sodium Adsorption Ratio (SAR) which also predicts the Exchangeable Sodium Percentage (ESP). This method is therefore routinely used where salinity is a concern. The cations analyzed in saturation extracts are Ca, Mg, K, and Na, while the anions are  $\text{SO}_4$  (sulfate),  $\text{CO}_3$  (carbonate),  $\text{HCO}_3$  (bicarbonate) and Cl (chloride).

### *Materials needed:*

- Ceramic dishes
- Spatulas or mixing spoons
- Vacuum filtration system
- Weighing scale
- Water (deionized if possible)
- Filter paper
- Small bottle to collect the filtrate
- Electrical conductivity meter

### *Procedure:*

- Weigh 200-300 g of air-dried soil (< 2-mm) into a ceramic dish.
- Slowly add water (deionized if possible), and mix until the soil becomes a paste, which means that there is no visible water on the surface of the paste.
- Let the paste settle for 1 hour, and add more water if needed to obtain a paste as described above.
- Leave the paste for around 12 hours (up to 16 hours) and then filter with a vacuum filtration system using a Buchner funnel fitted with a filter paper.
- Collect filtrate in a small bottle and keep it for subsequent measurements for electrical conductivity (see the above method).

### *Advantages:*

- This method is accurate.

### *Disadvantages:*

- The results can differ depending on soil texture and initial soil water content.
- It requires technical expertise as each sample requires different amounts of water added to it.
- This method requires many materials in order to get accurate results.
- The method is expensive.
- See disadvantages for method 1.

# Method 3: Electrical conductivity using the 1:1 ratio method

## *Description:*

The 1:1 ratio method is an easy method to measure soil salinity using as little materials as possible. It is fast and inexpensive and gives a good idea of the salinity in a field. As with the two other methods for measuring soil salinity, it does require the use of an apparatus for measuring electrical conductivity.

## *Materials needed:*

- Soil sample
- Water
- Apparatus for measuring electrical conductivity
- Mixing cup
- Electrical conductivity meter

## *Procedure:*

- Obtain a soil sample and add the same ratio of water to the sample. For example, 10mL of water are added to 10g of soil.
- Mix the sample of soil with the sample of water and let it settle for around 20 minutes.
- After 30 minutes, the electrical conductivity is measured (see method 1 for measuring electrical conductivity).

## *Advantages:*

- This method is fast and easy. It does not require much technical knowledge.
- This method is cheap and can therefore be used for a larger number of samples to determine differences between different areas of a same field.

## *Disadvantages:*

- While cheap, fast and easy, this method requires an apparatus that might not be available everywhere and is quite expensive.
- It is relatively accurate but is less accurate than other methods (described above).
- See disadvantages for method 1.



# Method 4: Presence of sulphates and chlorides

## Description

Many of the soluble salts responsible for salinity are sulphates (as thenardite  $\text{Na}_2\text{SO}_4$  or mirabilite  $\text{Na}_2\text{SO}_4 \cdot 10\text{H}_2\text{O}$ ) or chlorides (as halite  $\text{NaCl}$  or silvite  $\text{KCl}$ ). Knowing the nature of the salinity may help to find an appropriate treatment. The presence of sulfate ( $\text{SO}_4^{2-}$ ) or chloride ( $\text{Cl}^-$ ) ions in the solution can easily be detected in the field with two specific reagents containing barium or silver cations to make them precipitate as barium sulphate ( $\text{BaSO}_4$ ) or silver chloride ( $\text{AgCl}$ ) respectively. The method to detect sulphates is also useful to determine the presence of gypsum ( $\text{CaSO}_4 \cdot 2\text{H}_2\text{O}$ ), which is not considered a soluble salt (solubility around 2.3 g/l) (Porta and Lopez-Ácevedo, 2005).

## Materials needed

- 2 test tubes (glass or transparent plastic)
- Small funnel
- Filter paper
- $\text{BaCl}_2$  (barium chloride) 10% solution (to detect sulphates) or
- $\text{AgNO}_3$  (silver nitrate) 5% solution (to detect chlorides)
- Small knife or spatula
- Deionized water

## Procedure

Take a small portion of soil with the tip of the spatula and place it in the test tube. Add deionized water so that the heigh proportion soil/water is approximately 1/10, stop it with your thumb and shake vigorously for some seconds. Place the funnel in the second test tube, cover it with the filter paper, and pour in the mixture to be filtered. Wait for some minutes until you have about 1 cm of filtrate. Add one drop of the barium chloride (to detect sulfates) or silver nitrate (to detect chlorides) to the filtrate. If a cloud of precipitate is formed it contains sulfates or chlorides.

## Advantages

· Very fast field test that may be applied to soils, salt crusts, accumulations, or even waters directly (groundwater, irrigation water).

## Disadvantages

· It is a qualitative test that cannot measure the absolute amount of salts, additional lab measurements are needed.

## Method 5: Field symptoms (visual symptoms of soil salinity)

### *Description:*

Saline soils contain very high proportions of soluble salts in both the soil solution and on clay particles, and most plants fail to grow in saline soils or their growth is altered significantly as can be observed using visual symptoms for assessing whether a soil is affected by salts or not. This method uses visual symptoms as indicators of soil salinity. (ICARDA, 2007).

Visual indicators of soil salinity can include the following:

- Patchy crop growth
- Bare soil
- Salt crystals on the soil surface
- Puffy dry soils
- The presence of salt tolerant species and weeds
- Light gray or white colors on the soil surface
- Some areas within a field can take longer to grow

Promoters and trainers are encouraged to display examples of soil salinity at the local level as the species of salt-tolerant plants and saline soils will differ by region, climate etc. Below are some examples of saline soils that could be used if relevant.

### *Advantages:*

- Looking at visual symptoms can be a good way of determining if a soil is saline in areas where salinity may be an issue due to different factors but no apparatus or laboratories are available to measure salinity.
- No materials are needed.
- This method is relatively cheap.

### *Disadvantages:*

- This method requires technical expertise and experience in salinity
- Visual symptoms can differ depending on the soil type and climate.
- In a cultivated soil, there may be no visual indicators of soil salinity.
- When visual indicators are present, it might be too late as the soil may already be high in salinity.
- This method is not very accurate.





# Soil biological properties

## Biological activity

What it is and why it is important:

Soil biological activity is a soil parameter that can be used as an indicator for the functioning of the soil, that is, its quality or health. It is based on the assumption that the biological component of soil is one of the most important characteristics in determining the health of a soil as it consists of the living components – soil macro/micro-organisms. Soil biological activity is therefore the tool that is used to assess or determine the health of a soil. Its importance stems from the fact that soil microorganisms are critical in crop nutrient cycling and nutrient availability for crop uptake by the decomposition of soil organic matter.

As an aggregate of several components, soil biological activity can be measured or assessed by different soil properties, including the diversity and abundance of microbial populations, the rate at which these organisms decompose the soil organic matter and the evolution of carbon dioxide in the process. In these processes, the assumption is that, the more diverse and abundant the organisms and the faster the rate at which soil organic matter is decomposed, the higher the quality of that soil.

Proposed methods to assess soil biological activity in the field are reported in Table 12.

TABLE 12. METHODS TO ASSESS SOIL BIOLOGICAL ACTIVITY IN THE FIELD

Method	Low cost	Low technology	High accuracy	Low difficulty	Low need for training	Low maintenance or need to replace components	Less time consuming
Earthworm count	***	***	**	***	**	***	**
The teabag method	***	***	**	**	**	***	**
Active/labile carbon	*	**	**	***	***	***	**
Soda-lime method	*	*	***	*	*	*	**

EVALUATION SYSTEM FOR THE METHODS/ EQUIPMENT EVALUATED AS FOLLOWS: FIELD SUITABILITY (\*) LOW, (\*\*\*) MEDIUM, (\*\*\*) HIGH.

# Method 1: Earthworm density

## *Description:*

Assessing earthworm density is a soil biological activity method that consists of counting the number of earthworms (abundance) per unit area in the field. The assumption of the method is that the higher the count, the better the soil quality. This assumption is based on certain functional roles that earthworms have on the soil, such as accelerated organic matter decomposition, enhanced soil physical structure and nutrient cycling caused by their feeding and burrowing activities. In addition to the number, the identification of earthworm species can be also very informative about their ecological role.

## *Materials needed:*

- Tape measure
- Marking signs (sticks, wire or wooden frames)
- Tap water (quantity will depend on the area of sampling)
- Spade (flat blade if possible) or a hand trowel or shovel
- Large plastic sheets or trays
- Plastic containers with lids for collection of worms to be counted
- Tweezers/forceps, labels, permanent markers
- Solution of mustard powder. This powder is dissolved into the water to make a solution (two tablespoons per two liters of water)
- Cool box and ice packs

## *Procedure*

- First, identify the sampling area within the field and then clear the area of any surface vegetation. If there is a litter layer, transfer it onto a plastic sheet or tray and sort the earthworms manually.
- Using a tape measure, measure a square meter in the field as the sampling area and dig up to a 20 – 30 cm into the ground. This depth is an equivalent of most plant root depth.
- Place the dug soil block on the plastic sheet, sort through the soil manually, remove all earthworms and place them in labelled plastic containers. If possible, differentiate worms by type and place them into different collecting containers and label accordingly.
- **(Optional or as additional step):** level out the bottom of the hole, and pour the mustard solution slowly in the already dug soil pit (hole). Deep burrowing worms should come to the surface after some time after adding the solution. Then collect worms into their respective containers. Keep the containers away from the sunlight and in a cool area (in the cool box) until they can be processed
- Then finally count and record the total number of earthworms that are/were collected. The number of earthworms is recorded per their unit area of collection (i.e. number of earthworms/sampling area, which is normally a square meter)



## Method 2: Litter decomposition (tea bag method)

Description:

The decomposition process represents a major flux of both fixed carbon and nutrients in most terrestrial ecosystems including cultivated ecosystems and or rangeland ecosystems, and quantifying rates of litter mass loss (decomposition) and the associated changes in nutrients bound in soil organic matter are important aspects of evaluating ecosystem functions. Plant litter decomposition is an important soil biological process that determines carbon and nutrient accumulation, and more the rate and timing of nutrient release in the forms that are available to plants and crops as well as soil organisms. Determination of the timing and release of nutrients is crucial in their synching with crop nutrient demands and in particular in the organically managed systems or under smallholder systems that are less reliant on chemical fertilizers for crop and or plant nutrition. Litter decomposition along with nutrient dynamics such as their cycling are controlled by different factors including the nature of the organic material, soil properties such as temperature, moisture, acidity and microbial populations. The rate at which the organic (litter) material is decomposed and nutrient cycled within the soil can be an important aspect of evaluating an ecosystem function or the effectiveness of a certain management practice (e.g. conservation agriculture vs conventional agriculture).

There are several methods that could be used to determine litter decomposition; the teabag method is one of these methods. It is simple and can be implemented by farmers in the field without having to rely on technical experts. The method consists of measuring the mass loss of a certain organic material. A known mass of organic material (teabag) is buried in the field for a certain period of time and then recovered to determine the percentage of its lost mass during the field incubation.

### **Materials needed:**

- Teabags (be careful of the bags including material and their mesh size)
- Weighing scale
- Collection/ carrying bags after teabag recovery from the field
- Pegs for tagging of the teabag burial site during field incubation for ease of identification during the retrieval time

### **Procedure:**

- Air dry the teabags for about 7 seven days before their incubation in the field
- After air drying, measure the weight of each teabag (this weight will be the initial weight before decomposition)
- Then take the teabags to the field for their incubation
- Following the principles of sampling, identify at least 4 sites per each field to incubate the teabags
- Burry the teabags into the soil to a depth of about 7 cm below the soil surface. After teabag placing into the soil, place a flagging peg close to the buried teabag to mark its location for recovery after the incubation time. Clearly identify the treatments to which the bags are placed and label accordingly for record keeping.

## Soil biological properties

- Leave the teabag incubated in the field for a period of 3 months
- After 3 months of field incubation, recover the teabags from the field. Make sure to remove some of the organic materials attached to the teabag, including some soil.
- After their collection from the field, air dry the teabags for a period of 7 days and then measure their weight (this would be the final weight)
- Then perform the calculations to determine the percentage of litter mass that was lost during the incubation period.

**Calculation:** *Percentage of mass loss* =  $\left( \frac{W_i - W_f}{W_i} \right) * 100$

**Where:**

$W_i$  = initial teabag weight before field incubation (grams)

$W_f$  = final teabag weight after field incubation (grams)

### **Advantages:**

- It is easy and straightforward.
- It does not require any specialized or specific skills.

### **Disadvantages:**

- The method can underestimate the decomposition rate as some of the soil organisms are excluded from the litter bags
- The method alters the microclimate under which decomposition occurs and can therefore either delay or accelerate the decomposition process
- The method does not allow to study the effect of soil texture or structure on decomposition as the litter is separated from the entire soil environment

### **Suitability: (climate, crops, soil types)**

- Under soils with high soil organic matter content the method may overestimate the decomposition process.
- Under humid climate, the dissolved organic carbon in the soil surrounding may get into the litter bags and could underestimate the decomposition process and lead to the assumption that little mass was lost from the litter.

# Method 3: Active/labile carbon

## *Description:*

Active carbon is a fraction of total soil organic matter that can easily be decomposed by soil organisms and it therefore shows soil organic matter that is readily available as energy for microbial community and potentially mineralizable plant nutrients. This fraction of carbon can be used as an indicator of soil biological activity and therefore of soil health. The method is based on the ability of labile carbon to be easily oxidized by a mild to strong oxidizing agent and thereafter observing the color change on oxidizing agent. The soil is mixed with a known concentration of potassium permanganate ( $\text{KMnO}_4$ ), an oxidizing agent (which is deep purple in color) and as the oxidation process continues, the color of the potassium permanganate changes to a less purple color which can be observed virtually but could further be accurately measured with a spectrophotometer to determine the absolute quantities of available active carbon. However, for simple field assessments, a virtual color change could be sufficient in the absence of a portable hand colorimeter.

The active/labile soil carbon could be used as an indicator of soil biological activity and as such could be used to indicate some response to soil management practices. It is positively correlated with some soil biological activity indicators such as soil respiration, soil microbial biomass and potential mineralizable nitrogen. Unlike soil organic matter or total soil organic carbon, the labile carbon responds quickly to soil management practices and this makes it a good indicator of best management practice.

## *Materials needed:*

- 0.02M potassium permanganate (0.02M  $\text{KMnO}_4$ )
- Transparent centrifugal tubes with caps (~50-100ml)
- Weighing scale
- Teaspoon
- Black plastic (waste disposal plastic bags) or a black tray
- Timer
- Hand held colorimeter (if available)
- 0.1M Calcium Chloride (0.1M  $\text{CaCl}_2$ ) if available (optional)

## *Procedure:*

- Obtain a representative soil sample of about 50g per sampling site.
- Spread the soil over a black waste disposal black plastic bag or tray and let the sample air dry in the sun for about 15 minutes.
- Hand crush the soil to consistent particle size (this step is to replace soil sieving if there is no sieve available).
- Then measure a 5g soil and put it in the centrifugal tubes.
- Add about 35ml of 0.02M  $\text{KMnO}_4$  and shake the solution for about 2 minutes by hand.
- Let the solution to settle for about 5 minutes.

## Soil biological properties

- Then wait for the soil solution to change color. Potassium permanganate has a deep blue purple color, if the color of the solution in the tube will change to become less purple after mixing the soil with  $\text{KMnO}_4$  that indicates that the labile organic carbon in the soil is being oxidized. Thus, when comparing two samples from different management practices, the soil that will result with the least vibrant purple color indicates high concentrations of labile carbon as the fraction of total soil organic carbon.
- **Optional:** To further quantify the color change of the solution, a hand held colorimeter could be used. Using the pipette, draw a 0.1mL solution from the centrifugal tubes and then dilute with a 10mL deionized water and read its color absorbance at the 550nm wavelength using the hand held colorimeter. To facilitate the rapid settling of soil particles to give a clear supernatant solution that will not interfere with the color reading, add to the soil solution a 0.1M  $\text{CaCl}_2$  solution. This helps soil particles flocculate and settle faster during the soil-settling period.

### Advantages:

- The method is simple if training and equipment are available
- The method is quite inexpensive and is applicable at the field level .

### Disadvantages:

- If the colorimeter is not available, the method does not give a quantitative measure of labile organic carbon but just an indication of available labile organic carbon.
- The effectiveness of the method depends on the concentration of the active carbon in the soil. With higher carbon concentrated soils, the method may underestimate the amount of active/labile carbon in the soil.

### Suitability: (climate, crops, soil types)

- Under soils with high organic matter content such as peat soils (Histosols) or Mollisols, the method may result in lower estimates of labile/active organic carbon. This happens because the concentration and quantity of  $\text{KMnO}_4$  may not suffice to complete the oxidation process. Under such soil types, it would be necessary to determine the exact concentration of  $\text{KMnO}_4$  (other than the 0.02M that is recommended here). In addition, if the colorimeter is available for use, the high concentration of carbon in the sample may interfere with the exact determination of the active/labile carbon.

### Note:

Making a 0.02M solution of  $\text{KMnO}_4$

Molar mass of  $\text{KMnO}_4 = 39 (\text{K}) + 55 (\text{Mn}) + 16 \times 4 (\text{O}) = 158\text{g/mol}$

So 0.02 M  $\text{KMnO}_4 = 0.02 \text{ mol/L} \times 158 \text{ g/mol} = 3.16\text{g/L } \text{KMnO}_4$

Thus, to make a 0.02M  $\text{KMnO}_4$ , dissolve 3.16g of  $\text{KMnO}_4$  in 1L of deionized water



# Method 4: Soil respiration – soda lime

## *Description:*

Soil respiration is the process through which carbon dioxide is released from the soil. This carbon dioxide results from plant root respiration and microbial decomposition of soil organic matter and depending on the soil type, from the dissolution of carbonates within the soil. Soil respiration is one of the soil processes that are used to measure soil biological activity. It is a useful indicator that can be used to assess the effectiveness of soil management practices. The idea is based on the premise that best management practices result in high accumulation of soil organic matter and abundant and diverse microbial populations. Soils with these properties would therefore result in larger quantities of carbon dioxide, which reveals soil microbial activity.

There are several methods that are used to estimate soil respiration, some of which are carried out within the laboratory, while others are used in the field. Soda lime, a mixture of calcium oxide and sodium hydroxide, is used to measure soil respiration in the field. The method is based on the ability of soda lime to absorb carbon dioxide. This results in soda lime increasing in mass as a result of carbon dioxide absorption. The mass gain as a result of carbon dioxide absorption, is assumed to be the amount of carbon dioxide that was released from the soil. A known mass of soda lime is left to stay in the field for a period of 24 hours within a closed chamber. Then after retrieval from the field, the soda lime will be reweighed to measure the change in weight. The difference between the initial and final weight of the soda lime reflects the amount of carbon dioxide released from the soil. Following is the chemical reaction of the process:

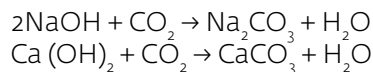

## *Materials needed:*

- Soda lime (a mixture of calcium oxide and sodium hydroxide)
- Chamber (this could be even the lid of the food warmer used in restaurants or any cylindrical shaped metal that could be driven into the soil or a bucket that used to contain water within households). White or silver materials are preferred.
- Aluminum foil
- Analytical weighing scale (that displays a result of at least two decimal places).
- An oven (or microwave oven if not available, see the method on using a microwave oven to dry soils in the annex).
- Ceramic cups or glass material
- A desiccator (if available)
- Water sprayer (hair spray bottles could be used, as well as any container that has a spray head)
- Water
- Wire stand

## Procedures

- **Chamber assembly and installation in the field**
  - The chambers could be polyethylene plastic buckets with the base cut off. The bucket should have an internal diameter of about 30 to 40 cm. The bucket should have a well-sealed lid. Flexibility can be exercised depending on the materials available; however, the lid should be properly sealed, as this is critical in preventing gaseous movement in and out of the chamber. White colored chambers are preferable to dark colored in order to reduce heat accumulation within the chamber. To further reduce heat accumulation, an aluminum foil could be used to cover the chamber to reflect away the sunrays.
  - The bucket lid should have at least 2 cm depth around the edge to allow for a proper sealing.
  - Chambers will need to be placed in the field and inserted into the ground (1-2cm deep) some weeks (1-3) before measurements could be carried out. This helps to reduce the effects of soil disturbance in the measured carbon dioxide. After inserting the chamber into the ground, leave them open until the placing of the soda lime so as to avoid carbon dioxide accumulation within the chamber.
  - To reduce the effect of vegetation within the chamber, clip all the vegetation to the ground
  - During the placement in the field, put some weight (stone) on top of the lid to firmly secure it.
  - A means of a control will be needed. This could be achieved by using similar plastic material but with the sealed base to avoid the soil conduct with the inside of the bucket. This helps to control for any atmospheric carbon dioxide that may diffuse into the bucket during the measurement process.

**FIGURE 2 | ILLUSTRATION DESIGN FOR THE CHAMBER INSERTED INTO THE SOIL, WITH CERAMIC CUPS CONTAINING SODA LIME ON WIRE STAND. 8.4 CM IS THE HEIGHT OF THE CHAMBER ABOVE THE SOIL SURFACE - THIS SPACE GIVES THE HEAD SPACE OF THE CHAMBER THAT ALLOWS FOR THE EFFLUX OF CARBON DIOXIDE. 1 CM IS THE DEPTH TO WHICH THE CHAMBER IS INSERTED INTO THE SOIL.**

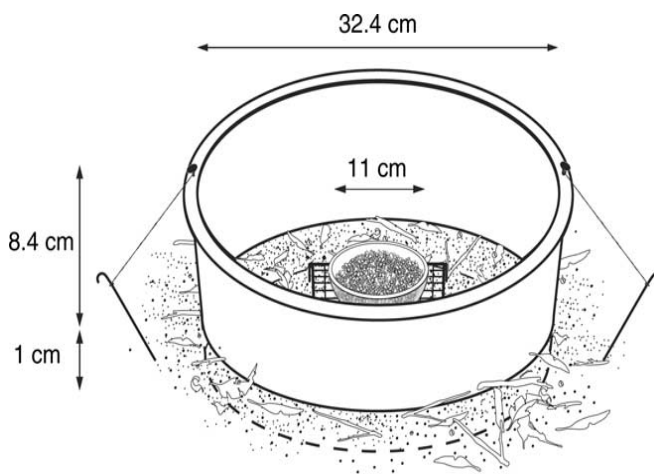

- Soda Lime

- Using an inert ceramic cup of about 10-15 cm diameter, weigh about 50g of soda lime granules. The granules should not be of fine texture. A 4-8 mesh size (2.4 – 4.8mm diameter granules) are of the ideal size.
- Oven dry (or by any means available) the soda lime at 105°C to reach a constant weight. 14 hours should suffice. Then allow the soda lime to cool for about 30 minutes. While cooling, cover the ceramic cup containing the soda lime with a cloth to prevent carbon dioxide in the room to be absorbed into the soda lime and also to absorb some humidity in the room so as not to be absorbed on to the soda lime.
- Then weigh the dried soda lime to have a dry weight.
- Tightly seal the ceramic cups after weighing to avoid atmospheric carbon dioxide to be absorbed onto the soda lime. Then put them in the box to be transported to the field.
- At the field, carefully untie the ceramic cups containing the soda lime and spray the soda lime with water (8 ml). Make sure that all the granules are sprayed evenly. This water is equivalent to the amount of water that was lost during soda lime drying. This moisture is required in order to allow the reaction of carbon dioxide with the hydroxide in the soda lime. That is, this reaction happens only in the presence of water.
- Then place the ceramic cups containing the soda lime in the chambers (plastic buckets) that have been pre-placed in the field. Use the wire stand (or anything that will not affect the efflux of carbon dioxide from the soil) to place the ceramic cups on top.
- After placing the soda lime in the chamber, carefully close the chamber with its lid, put some weight (stone) on it to keep the lid in place. Then wait for about 24 hour period. Precisely record the time elapsed between the chamber closure and soda lime retrieval so as to have the exact time of incubation calculated. This procedure should exactly be carried out for the control treatment as well. That is, the chamber that has excluded the soil environment into its interior.
- After a day of incubation, collect the soda lime from the field. Make sure that the ceramic cups containing soda lime is tightly sealed like when it was brought to the field and pack in the box to be transported to a place where it will be dried again and reweighed.
- Then oven dry the soda lime in the ceramic cups for 14 hours, wait 30 minutes for their cooling and reweigh them again. Perform similar task even for the control treatment. The control measurement are carried out so as to account for carbon dioxide that was absorbed by the soda lime during the experimental procedure.
- Then perform the calculation to determine the carbon dioxide flux, which is soil respiration.

### • **Calculations:**

- This method is based on the ability of soda lime to adsorb carbon dioxide that is measured by weight gain. Following is the equation that governs the process:

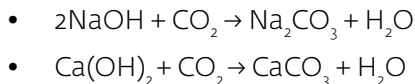

- $$\text{CO}_2 \text{ efflux} = \left( \left( \frac{Sw - Cw}{CA} \right) * 1,69 \right) * \left( \frac{24h}{IP} \right) * \left( \frac{12}{44} \right)$$

- **Where:**

- **CO<sub>2</sub> efflux** = soil respiration = soil carbon dioxide efflux (g-C m<sup>-2</sup> day<sup>-1</sup>)
- **Sw** = soda lime weight difference = the difference in weight of soda lime after incubation and before incubation (g)
- **Cw** = control soda lime weight difference = the difference in weight of control soda lime after incubation and before incubation (g)
- **CA** = chamber surface area (m<sup>2</sup>)
- **IP = incubation period** = the number of hours that soda lime was incubated in the field (hours)
- **24 h** = 24 hour period during which the soda lime incubation is supposed to happen
- **1.69** = the correction factor used to account for water formed during chemical absorption of carbon dioxide by soda lime and released during drying.
- **12/44** = carbon dioxide correction factor. (For every mole of carbon dioxide that chemically reacts with soda lime, one mole of water is formed that is subsequently evaporated during drying. That is, the increase of soda lime dry mass after incubation underestimates carbon dioxide absorbed by a factor of 40.09% (12/44)).

### **Advantages:**

- The method is easily applicable for large scale fields that require spatial replication, temporal integration and long term monitoring
- It is an accurate method to measure soil respiration with the materials used being readily available or not hard to find
- It is relatively faster compared to other standard methods for determining soil respiration

### **Disadvantages:**

- It depends highly on soil conditions such as soil temperature, moisture and texture, which makes it not universally applicable.
- It may result in a false positive that overestimates microbial soil respiration by

including some root respiration especially under grasslands or pastures, with myriad of fine grass roots.

- The analytical weighing scale needs to display results with at least two decimal places, which can be an issue if such a scale is not available, as the results would not yield accurate results.

**Suitability: (climate, crops, soil types)**

- It works well under medium textured soils
- It does not perform well under humid climates

Notes	

# Annex I: Visual soil assessments

---

## *Description:*

Soil physical properties are crucial to the well-functioning of a soil and farm productivity. They control the movement of water and air through the soil, and the ease with which roots can penetrate the soil. Soil degradation can lead to changes in these properties and decrease crop productivity, even under appropriate soil nutrient status. A decline in the physical quality of a soil can be hard to remediate, and can increase the risk of other soil degradation processes such as soil erosion.

The Visual Soil Assessment is an assessment produced by the Food and Agriculture Organization in 2008, which is based on the visual assessment of key soil 'state' and plant performance indicators of soil quality, presented on a scorecard. With the exception of soil texture, the soil indicators are dynamic indicators, i.e. capable of changing under different management regimes and land-use pressures. Being sensitive to change, they are useful early warning indicators of changes in soil condition and as such provide an effective monitoring tool.

Many physical, but also biological and, to a lesser degree, chemical soil properties can show up as visual characteristics. In this context, soil health can be assessed through visual assessments and symptoms in the field. This section will look at visually assessing the following soil characteristics:

1. Soil texture
2. Soil structure and consistency
3. Soil porosity
4. Soil color
5. Number and color of mottles
6. Earthworm count
7. Potential rooting depth
8. Surface ponding
9. Surface crusting and surface cover
10. Soil erosion

## *Materials needed to carry out this assessment are:*

- A spade
- A plastic basin
- A hard square board
- A heavy-duty plastic bag
- A knife.
- A water bottle.
- A tape measure.
- This document to compare your field to the visual representations of soil.
- A pad of scorecards (below)

## Before getting started:

When should a Visual Soil Assessment be carried out?

The test should be carried out when the soils are **moist** and **suitable for cultivation**. If you are not sure about the conditions of your soil, use the worm test in order to determine if they are suitable for this method.

### The worm test

Roll a worm of soil on the palm of one hand with the fingers of the other until it is 50 mm

long and 4 mm thick. If the soil cracks before the worm is made, or if you cannot form a worm (for example, if the soil is sandy), the soil is suitable for testing. If you can make the worm, the soil is too wet to test.

Setting up for the visual soil assessment test:

**Time:** You should allow for around 25 minutes per site. Four sites should be sampled over a 5-ha area for a representative assessment of soil quality.

**Reference sample:** Take a soil sample (100x50x100 mm deep) from under a nearby fence or a similar protected area. This will provide you with a reference sample from an undisturbed sample. This will allow assigning the correct score for soil color as well as for comparing soil structure and porosity.

**Site location:** It is important to select sites that are representative of the field. Because the condition of the soil within a field is site specific, it is also important to avoid certain areas such as those with a heavier traffic.

**Site information:** Complete the site information at the top of the scorecard below. Record any information that you think are relevant in the notes section of the scorecard.

### The visual soil assessment test:

The Visual Soil Assessment is based on the visual assessment of key soil 'state' and plant performance indicators of soil quality, presented on a scorecard. With the exception of soil texture, the soil indicators are dynamic indicators, i.e. capable of changing under different management regimes and land-use pressures. Being sensitive to change, they are useful early warning indicators of changes in soil condition and as such provide an effective monitoring tool.

**Initial observation:** The first step of this assessment involves digging a small hole of about 200 x 200 mm square by 300 mm deep with a spade and to observe the topsoil and upper subsoil if it is present. It is important to note its uniformity as well as whether it is soft and friable or hard and firm. A knife can be used for this initial observation.

**Taking the test sample:** If the topsoil looks uniform, dig out a 200-mm cube of soil using a spade. The sampling can be done at the depth desired, but is it important to ensure that the sample is a 200 mm cube of soil.

**The drop shatter test:** Drop the test sample (above) a maximum of three times from a height of 1 meter onto the wooden square in the plastic bin. The number of times the sample is dropped from and the height at which is dropped, give an idea of the soil texture and the degree to which the soil breaks up.





# 1. Soil texture

## *Relevance and importance:*

Soil texture defines the size of the mineral particles. Specifically, it refers to the relative proportion of the various size-groups in the soil, i.e. sand, silt and clay. Sand is that fraction that has a particle size  $>0.06$  mm; silt varies between  $0.06$  and  $0.002$  mm; and the particle size of clay is  $<0.002$  mm. Texture influences soil behavior in several ways, notably through its effect on: water retention and availability; soil structure; aeration; drainage; soil workability and trafficability; soil life; and the supply and retention of nutrients. A knowledge of both the textural class and potential rooting depth enables an approximate assessment of the total water-holding capacity of the soil, one of the major drivers of crop production.

## *Procedure:*

- Take a small sample of soil (half the size of your thumb) from the topsoil and a sample (or samples) that is (or are) representative of the subsoil.
- Wet the soil with water, kneading and working it thoroughly on the palm of your hand with your thumb and forefinger to the point of maximum stickiness.
- Assess the texture of the soil according to the criteria given in the table below by attempting to form a ball with the soil.
- With experience, a person can assess the texture directly by estimating the percentages of sand, silt and clay by feel, and the textural class obtained by reference to the textural diagram.
- There are occasions when the assignment of a textural score will need to be modified because of the nature of a textural qualifier. For example, if the soil has a reasonably high content of organic matter, i.e. is humic with 15–30 percent organic matter, raise the textural score by one (e.g. from 0 to 1 or from 1 to 2). If the soil has a significant gravelly or stony component, reduce the textural score by 0.5.
- There are also occasions when the assignment of a textural score will need to be modified because of the specific preference of a crop for a particular textural class.

### **How to score soil texture**

**Good score** (2 points): The textural class is a silt loam. The soil texture is smooth and has a soapy feel. It is slightly sticky and contains no grittiness. It moulds into a ball that produces fissures when it is pressed flat on the palm of the hand.

**Moderately good score** (1.5 points): The textural class is a clay loam. The soil texture is very smooth, sticky and plastic. It moulds into a ball that deforms without fissuring when pressed flat. **Moderate score** (1 point): The textural class is a sandy loam. The soil texture is slightly gritty. It moulds into a cohesive ball that pressures when pressed flat.

**Moderately poor score** (0.5 points): The textural class is a loamy sand, a silty clay or clay. For the loamy sand, the soil texture is gritty with a faint rasping sound. It moulds into a ball that disintegrates when pressed flat. For the silty clay and the clay, the texture is very smooth, very sticky and very plastic. It moulds into a cohesive ball that deforms when pressed flat without any fissures.

**Poor score** (0 points): The textural class is sand. The soil texture is gritty with a rasping sand, and it cannot be moulded into a ball.

A2. TEXTURAL CLASSES - ADAPTED FROM FAO'S GUIDELINES FOR SOIL DESCRIPTION, 2006

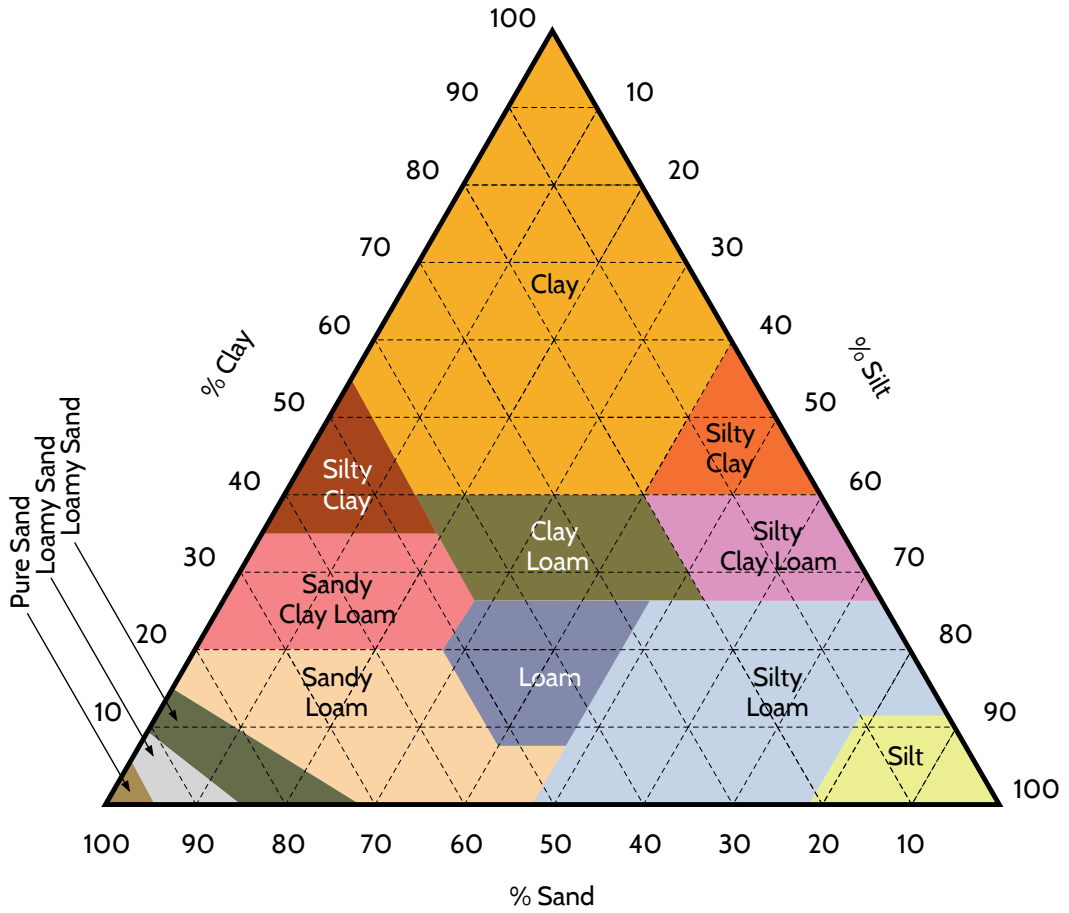



## 2. Soil structure and consistency

### *Relevance and importance:*

- Soil structure is extremely important for arable cropping. It regulates:
- soil aeration and gaseous exchange rates;
- soil temperature;
- soil infiltration and erosion;
- the movement and storage of water;
- nutrient supply;
- root penetration and development;
- soil workability;
- soil trafficability;
- the resistance of soils to structural degradation.

Good soil structure reduces the susceptibility to compaction under wheel traffic and increases the window of opportunity for vehicle access and for carrying out no-till, minimum-till or conventional cultivation between rows under optimal soil conditions. Soil structure is ranked on the size, shape, firmness, porosity and relative abundance of soil aggregates and clods. Soils with good structure have friable, fine, porous, subangular and subrounded (nutty) aggregates. Those with poor structure have large, dense, very firm, angular or subangular blocky clods that fit and pack closely together and have a high tensile strength.

### *Procedure:*

- Remove a 200-mm cube of topsoil with a spade (between or along wheel tracks).
- Drop the soil sample a maximum of three times from a height of 1 m onto the firm base in the plastic basin. If large clods break away after the first or second drop, drop them individually again once or twice. If a clod shatters into small (primary structural) units after the first or second drop, it does not need dropping again. Do not drop any piece of soil more than three times. For soils with a sandy loam texture, drop the cube of soil just once only from a height of 0.5 m.
- Transfer the soil onto the large plastic bag.
- For soils with a loamy sand or sand texture, drop the cube of soil still sitting on the spade (once) from a height of just 50 mm, and then roll the spade over, spilling the soil onto the plastic bag.
- Applying only very gently pressure, attempt to part each clod by hand along any exposed cracks or fissures. If the clod does not part easily, do not apply further pressure (because the cracks and fissures are probably not continuous and, therefore, are unable to readily conduct oxygen, air and water).
- Move the coarsest fractions to one end and the finest to the other end. Arrange the distribution of aggregates on the plastic bag so that the height of the soil is roughly the same over the whole surface area of the bag. This provides a measure of the aggregate-size distribution. Compare the resulting distribution of aggregates with the three photographs in Plate 2 and the criteria given.

The method is valid for a wide range of moisture conditions but is best carried out when the soil is moist to slightly moist; avoid dry and wet conditions.

## How to score soil structure

**Good condition** (2 points): Soil is dominated by friable and fine aggregates that do not show any significant signs of clodding. The aggregates are subrounded and porous.

**Moderate condition** (1 point): The soil contains both coarse clods and friable aggregates (50%). The coarse clods are firm, subangular or angular and there are few to no pores.

**Poor condition** (0 points): The soil is dominated with coarse clods and contains very little fine aggregates. The clods are firm, angular or subangular in shape and have very little to no pores.



**GOOD  
CONDITION**  
VS = 2

SOIL  
DOMINATED BY  
FRIABLE, FINE  
AGGREGATES  
WITH NO  
SIGNIFICANT  
CLODDING  
AGGREGATES  
ARE GENERALLY  
SUBROUNDED  
(NUTTY) AND  
OFTEN QUITE  
POROUS.



**MODERATE  
CONDITION**  
VS = 1

SOIL CONTAINS  
SIGNIFICANT  
PROPORTIONS  
(50%) OF BOTH  
COARSE CLODS  
AND FRIABLE  
FINE  
AGGREGATES.  
THE COARSE  
CLODS ARE  
FIRM,  
SUBANGULAR  
OR ANGULAR IN  
SHAPE AND  
HAVE FEW OR  
NO PORES.



**POOR  
CONDITION**  
VS = 0

SOIL  
DOMINATED BY  
COARSE CLODS  
WITH VERY  
FEW FINER  
AGGREGATES.  
THE COARSE  
CLODS ARE  
VERY FIRM,  
ANGULAR OR  
SUBANGULAR  
IN SHAPE AND  
HAVE VERY  
FEW OR NO  
PORES.

## 3. Soil porosity

### *Relevance and importance:*

It is important to assess soil porosity along with the structure of the soil. Soil porosity, and particularly macroporosity (or large pores), influences the movement of air and water in the soil. Soils with good structure have a high porosity between and within aggregates, but soils with poor structure may not have macropores and coarse micropores within the large clods, restricting their drainage and aeration. Poor aeration leads to the build up of carbon dioxide, methane and sulphide gases, and reduces the ability of plants to take up water and nutrients, particularly nitrogen (N), phosphorus (P), potassium (K) and sulphur (S). Plants can only utilize S and N in the oxygenated sulphate ( $\text{SO}_4^{2-}$ ), nitrate ( $\text{NO}_3^-$ ) and ammonium ( $\text{NH}_4^+$ ) forms. Therefore, plants require aerated soils for the efficient uptake and utilization of S and N. The number, activity and biodiversity of micro-organisms and earthworms are also greatest in well aerated soils and they are able to decompose and cycle organic matter and nutrients more efficiently. The presence of soil pores enables the development and proliferation of the superficial (or feeder) roots throughout the soil. Roots are unable to penetrate and grow through firm, tight, compacted soils, severely restricting the ability of the plant to utilize the available water and nutrients in the soil. A high penetration resistance not only limits plant uptake of water and nutrients, it also reduces fertilizer efficiency considerably and increases the susceptibility of the plant to root diseases. Soils with good porosity will also tend to produce lower amounts of greenhouse gases. The greater the porosity, the better the drainage, and, therefore, the less likely it is that the soil pores will be water-filled to the critical levels required to accelerate the production of greenhouse gases. Aim to keep the soil porosity score above 1.

### *Procedure:*

- Remove a spade slice of soil (about 100 mm wide, 150 mm long and 200 mm deep) from the side of the hole and break it in half.
- Examine the exposed fresh face of the sample for soil porosity by comparing against the three photographs in Plate 3. Look for the spaces, gaps, holes, cracks and fissures between and within soil aggregates and clods.
- Examine also the porosity of a number of the large clods from the soil structure test. This provides important additional information as to the porosity of the individual clods (the intra-aggregate porosity).

## How to score soil porosity

**Good condition** (2 points): The soil has many macropores and coarse micropores both within and between the aggregates, which is characteristic of a soil with a good structure.

**Moderate condition** (1 point): The soil contains macropores and coarse micropores, however they are not very visible and can only be detected after close examination. The soil shows a moderate amount of consolidation.

**Poor condition** (0 points): The soil does not contain any visible macropores or coarse micropores. Soil clods are compact and have very little structure. The surface of the clods is smooth with little cracks or holes and can have sharp angles.



**GOOD  
CONDITION  
VS = 2**

SOILS HAVE MANY MACROPORES AND COARSE MICROPORES BETWEEN AND WITHIN AGGREGATES ASSOCIATED WITH GOOD SOIL STRUCTURE.



**MODERATE  
CONDITION  
VS = 1**

SOIL MACROPORES AND COARSE MICROPORES BETWEEN AND WITHIN AGGREGATES HAVE DECLINED SIGNIFICANTLY BUT ARE PRESENT ON CLOSE EXAMINATION IN PARTS OF THE SOIL. THE SOIL SHOWS A MODERATE AMOUNT OF CONSOLIDATION.



**POOR  
CONDITION  
VS = 0**

NO SOIL MACROPORES AND COARSE MICROPORES ARE VISUALLY APPARENT WITHIN COMPACT, MASSIVE STRUCTURELESS CLODS. THE CLOD SURFACE IS SMOOTH WITH FEW OR NO CRACKS OR HOLES, AND CAN HAVE SHARP ANGLES.

## 4. Soil color

### *Relevance and importance:*

Soil color is a very useful indicator of soil quality because it can provide an indirect measure of other more useful properties of the soil that are not assessed so easily and accurately. In general, the darker the colour is, the greater is the amount of organic matter in the soil. A change in color can give a general indication of a change in organic matter under a particular land use or management. Soil organic matter plays an important role in regulating most biological, chemical and physical processes in soil, which collectively determine soil health. It promotes infiltration and retention of water, helps to develop and stabilize soil structure, cushions the impact of wheel traffic and cultivators, reduces the potential for wind and water erosion, and indicates whether the soil is functioning as a carbon 'sink' or as a source of greenhouse gases. Organic matter also provides an important food resource for soil organisms and is an important source of, and major reservoir of, plant nutrients. Its decline reduces the fertility and nutrient-supplying potential of the soil; N, P, K and S requirements of crops increase markedly, and other major and minor elements are leached more readily. The result is an increased dependency on fertilizer input to maintain nutrient status. Soil color can also be a useful indicator of soil drainage and the degree of soil aeration. In addition to organic matter, soil color is influenced markedly by the chemical form (or oxidation state) of iron (Fe) and manganese (Mn). Brown, yellow-brown, reddish-brown and red soils without mottles indicate well-aerated, well-drained conditions where Fe and Mn occur in the oxidized form of ferric ( $\text{Fe}^{3+}$ ) and manganic ( $\text{Mn}^{3+}$ ) oxides. Grey-blue colors can indicate that the soil is poorly drained or waterlogged and poorly aerated for long periods, conditions that reduce Fe and Mn to ferrous ( $\text{Fe}^{2+}$ ) and manganous ( $\text{Mn}^{2+}$ ) oxides. Poor aeration and prolonged waterlogging give rise to a further series of chemical and biochemical reduction reactions that produce toxins, such as hydrogen sulphide, carbon dioxide, methane, ethanol, acetaldehyde and ethylene, that damage the root system. This reduces the ability of plants to take up water and nutrients, causing poor vigor and ill-thrift. Decay and dieback of roots can also occur as a result of pests and diseases, including Rhizoctonia, Pythium and Fusarium root rot in soils prone to waterlogging.

### *Procedure:*

- Compare the color of a handful of soil from the field site with soil taken from under the nearest fence line or a similar protected area.
- Using the three photographs and criteria given, compare the relative change in soil color that has occurred.
- As topsoil color can vary markedly between soil types, the photographs illustrate the degree of change in color rather than the absolute color of the soil.



## How to score soil color

**Good condition** (2 points): The topsoil is dark colored. The color of the topsoil is not very different from that under the fenceline.

**Moderate condition** (1 point): The color of the topsoil is paler than that under the fenceline but the color difference is not striking.

**Poor condition** (0 points): The color of the soil is much paler than that under the fenceline.



**GOOD  
CONDITION  
VS = 2**

DARK COLOURED  
TOPSOIL THAT  
IS NOT TOO  
DISSIMILAR TO  
THAT UNDER THE  
FENCELINE.



**MODERATE  
CONDITION  
VS = 1**

THE COLOUR OF  
THE TOPSOIL  
IS SOMEWHAT  
PALER THAN  
THAT UNDER THE  
FENCELINE, BUT  
NOT MARKEDLY  
SO.



**POOR  
CONDITION  
VS = 0**

SOIL COLOUR  
HAS BECOME  
SIGNIFICANTLY  
PALER  
COMPARED WITH  
THAT UNDER THE  
FENCELINE.

## 5. Number and color of mottles

### *Relevance and importance:*

The number and color of soil mottles provide a good indication of how well the soil is drained and how well it is aerated. They are also an early warning of a decline in soil structure caused by compaction under wheel traffic and overcultivation. The loss of soil structure reduces the number of channels and pores that conduct water and air and, as a consequence, can result in waterlogging and a deficiency of oxygen for a prolonged period. The development of anaerobic (deoxygenated) conditions reduces Fe and Mn from their brown/orange oxidized ferric ( $\text{Fe}^{3+}$ ) and manganic ( $\text{Mn}^{3+}$ ) form to grey ferrous ( $\text{Fe}^{2+}$ ) and manganous ( $\text{Mn}^{2+}$ ) oxides. Mottles develop as various shades of orange and grey owing to varying degrees of oxidation and reduction of Fe and Mn. As oxygen depletion increases, orange, and ultimately grey, mottles predominate. An abundance of grey mottles indicates the soil is poorly drained and poorly aerated for a significant part of the year. The presence of only common orange and grey mottles (10–25 percent) indicates the soil is imperfectly drained with only periodic waterlogging. Soil with only few to common orange mottles indicates the soil is moderately well drained, and the absence of mottles indicates good drainage. Poor aeration reduces the uptake of water by plants and can induce wilting. It can also reduce the uptake of plant nutrients, particularly N, P, K, S and Cu. Moreover, poor aeration retards the breakdown of organic residues, and can cause chemical and biochemical reduction reactions that produce sulphide gases, methane, ethanol, acetaldehyde and ethylene, which are toxic to plant roots. In addition, decay and dieback of roots can occur as a result of fungal diseases such as Rhizoctonia, Pythium and Fusarium root rot, foot rot and crown rot in soils that are strongly mottled and poorly aerated. Fungal diseases and reduced nutrient and water uptake give rise to poor plant vigour and ill-thrift. If your visual score for mottles is  $\leq 1$ , you need to aerate the soil.

### *Procedure:*

- Take a sample of soil (about 100 mm wide  $\times$  150 mm long  $\times$  200 mm deep) from the side of the hole and compare with the three photographs and the percentage chart to determine the percentage of the soil occupied by mottles.
- Mottles are spots or blotches of different color interspersed with the dominant soil color.

## How to score soil mottles

**Good condition** (2 points): There are generally no mottles in the soil.

**Moderate condition** (1 point): The soil has a few fine and medium orange and grey mottles that can go from 10 to 25% of a soil sample.

**Poor condition** (0 points): The soil has medium and coarse orange and grey mottle at over 50%.



**GOOD  
CONDITION  
VS = 2**

**MOTTLES ARE  
GENERALLY  
ABSENT.**



**MODERATE  
CONDITION  
VS = 1**

**SOIL HAS  
COMMON  
(10-25%) FINE  
AND MEDIUM  
ORANGE AND  
GREY MOTTLES.**



**POOR  
CONDITION  
VS = 0**

**SOIL HAS  
ABUNDANT  
TO PROFUSE  
(>50%) MEDIUM  
AND COARSE  
ORANGE AND  
PARTICULARLY  
GREY MOTTLES.**

## 6. Earthworms

### *Relevance and importance:*

Earthworms provide a good indicator of the biological health and condition of the soil because their population density and species are affected by soil properties and management practices. Through their burrowing, feeding, digestion and casting, earthworms have a major effect on the chemical, physical and biological properties of the soil. They shred and decompose plant residues, converting them to organic matter, and so releasing mineral nutrients. Compared with uningested soil, earthworm casts can contain 5 times as much plant available N, 3–7 times as much P, 11 times as much K, and 3 times as much Mg. They can also contain more Ca and plant-available Mo, and have a higher pH, organic matter and water content. Moreover, earthworms act as biological aerators and physical conditioners of the soil, improving:

- soil porosity;
- aeration;
- soil structure and the stability of soil aggregates;
- water retention;
- water infiltration;
- drainage.

They also reduce surface runoff and erosion. They further promote plant growth by secreting plant-growth hormones and increasing root density and root development by the rapid growth of roots down nutrient-enriched worm channels. While earthworms can deposit about 25–30 tonnes of casts/ha/year on the surface, 70 percent of their casts are deposited below the surface of the soil. Therefore, earthworms play an important role in cropping soils and can increase growth rates, crop yield and protein levels significantly.

Earthworms also increase the population, activity and diversity of soil microbes. Actinomycetes increase 6–7 times during the passage of soil through the digestive tract of the worm and, along with other microbes, play an important role in the decomposition of organic matter to humus. Soil microbes such as mycorrhizal fungi play a further role in the supply of nutrients, digesting soil and fertilizer and unlocking nutrients, such as P, that are fixed by the soil. Microbes also retain significant amounts of nutrients in their biomass, releasing them when they die. Moreover, soil microbes produce plant-growth hormones and compounds that stimulate root growth and promote the structure, aeration, infiltration and water-holding capacity of the soil. Micro-organisms further encourage a lower incidence of pests and diseases. The collective benefits of microbes can increase crop production markedly while at the same time reducing fertilizer requirements.

Earthworm numbers (and biomass) are governed by the amount of food available as organic matter and soil microbes, as determined by the crops grown, the amount and quality of surface residues (Plate 6a), the use of cover crops and the method of tillage. Earthworm populations can be up to three times higher under no-tillage than conventional cultivation. Earthworm numbers are also governed by soil moisture, temperature, texture, soil aeration, pH, soil nutrients (including levels of Ca), and the type and amount of fertilizer and N used. The overuse of acidifying salt-based fertilizers, anhydrous ammonia and ammonia based products, and some insecticides and fungicides can further reduce earthworm numbers.

Soils should have a good diversity of earthworm species with a combination of: (i) surface feeders that live at or near the surface to breakdown plant residues and dung; (ii) topsoil-dwelling species that burrow, ingest and mix the top 200–300 mm of soil; and (iii) deep-burrowing species that pull down and mix plant litter and organic matter at depth. Earthworm species can further indicate the overall condition of the soil. For example, significant numbers of yellow-tail earthworms (*Octolasion cyaneum* – Plate 6b) can indicate adverse soil conditions.

**Procedure:**

- Count the earthworms by hand, sorting through the soil sample used to assess soil structure (Plate 7) and compare with the class limits in Table 2. Earthworms vary in size and number depending on the species and the season. Therefore, for year-to-year comparisons, earthworm counts must be made at the same time of year when soil moisture and temperature levels are good. Earthworm numbers are reported as the number per 200-mm cube of soil. Earthworm numbers are commonly reported on a square-metre basis. A 200-mm cube sample is equivalent to 1/25 m<sup>2</sup>, and so the number of earthworms needs to be multiplied by 25 to convert to numbers per square metre.

**How to score earthworms**

**Good visual score** (2 points): There are over 30 earthworms, preferably 3 or more species, in a 200-mm cube of soil.

**Moderate visual score** (1 point): There are between 15 and 30 earthworms, preferably 2 or more species, in a 200-mm cube of soil.

**Poor visual score** (0 points): There are less than 15 earthworms, with mostly 1 species, in a 200-mm cube of soil.



## 7. Potential rooting depth

### *Relevance and importance:*

The potential rooting depth is the depth of soil that plant roots can potentially exploit before reaching a barrier to root growth, and it indicates the ability of the soil to provide a suitable rooting medium for plants. The greater is the rooting depth, the greater is the available-water-holding capacity of the soil. In drought periods, deep roots can access larger water reserves, thereby alleviating water stress and promoting the survival of non-irrigated crops. The exploration of a large volume of soil by deep roots means that they can also access more macronutrients and micronutrients, thereby accelerating the growth and enhancing the yield and quality of the crop. Conversely, soils with a restricted rooting depth caused by, for example, a layer with a high penetration resistance such as a compacted layer or a hardpan, restrict vertical root growth and development, causing roots to grow sideways. This limits plant uptake of water and nutrients, reduces fertilizer efficiency, increases leaching, and decreases yield. A high resistance to root penetration can also increase plant stress and the susceptibility of the plant to root diseases. Moreover, hardpans impede the movement of air, oxygen and water through the soil profile, the last increasing the susceptibility to waterlogging and erosion by rilling and sheet wash.

The potential rooting depth can be restricted further by:

- an abrupt textural change;
- pH;
- aluminium (Al) toxicity;
- nutrient deficiencies;
- salinity;
- high compaction due to sodicity;
- a plough pan;
- cemented layers or bedrock near the surface;
- a high or fluctuating water table;
- low oxygen levels.

Anaerobic (anoxic) conditions caused by deoxygenation and prolonged waterlogging restrict the rooting depth as a result of the accumulation of toxic levels of hydrogen sulphide, ferrous sulphide, carbon dioxide, methane, ethanol, acetaldehyde and ethylene, by-products of chemical and biochemical reduction reactions. Crops with a deep, vigorous root system help to raise soil organic matter levels and soil life at depth. The physical action of the roots and soil fauna and the glues they produce, promote soil structure, porosity, water storage, soil aeration and drainage at depth. A deep, dense root system provides huge scope for raising production while at the same time having significant environmental benefits. Crops are less reliant on frequent and high application rates of fertilizer and N to generate growth, and available nutrients are more likely to be taken up, so reducing losses by leaching into the environment.

**Procedure:**

- Dig a hole to identify the depth to a limiting layer where present (Plate 8), and compare with the class limits (need to be established in a table). As the hole is dug, observe the presence of roots and old root channels, worm channels, cracks and fissures down which roots can extend.
- Note also whether there is an over-thickening of roots (a result of a high penetration resistance), and whether the roots are being forced to grow horizontally, otherwise known as right-angle syndrome. Moreover, note the firmness and tightness of the soil, whether the soil is grey and strongly gleyed owing to prolonged waterlogging, and whether there is a hardpan present such as a human-induced tillage or plough pan, or a natural pan such as an iron, siliceous or calcitic pan (pp 16–17). An abrupt transition from a fine (heavy) material to a coarse (sandy/gravelly) layer will also limit root development. A rough estimate of the potential rooting depth may be made by noting the above properties in a nearby road cutting or an open drain.



THE POTENTIAL ROOTING DEPTH EXTENDS TO THE BOTTOM OF THE ARROW, BELOW WHICH THE SOIL IS EXTREMELY FIRM AND VERY TIGHT WITH NO ROOTS OR OLD ROOT CHANNELS, NO WORM CHANNELS AND NO CRACKS AND FISSURES DOWN WHICH ROOTS CAN EXTEND..

## 8. Surface ponding

### *Relevance and importance:*

Surface ponding and the length of time water remains on the surface can indicate the rate of infiltration into and through the soil, a high water table, and the time the soil remains saturated. Prolonged waterlogging depletes oxygen in the soil causing anaerobic (anoxic) conditions that induce root stress, and restrict root respiration and the growth of roots. Roots need oxygen for respiration. They are most vulnerable to surface ponding and saturated soil conditions in the spring when plant roots and shoots are actively growing at a time when respiration and transpiration rates rise markedly and oxygen demands are high. They are also susceptible to ponding in the summer when transpiration rates are highest. Moreover, waterlogging causes the death of fine roots responsible for nutrient and water uptake. Reduced water uptake while the crop is transpiring actively causes leaf desiccation and the plant to wilt. Prolonged waterlogging also increases the likelihood of pests and diseases, including Rhizoctonia, Pythium and Fusarium root rot, and reduces the ability of roots to overcome the harmful effects of topsoil-resident pathogens. Plant stress induced by poor aeration and prolonged soil saturation can render crops less resistant to insect pest attack such as aphids, armyworm, cutworm and wireworm. Crops decline in vigour, have restricted spring growth (RSG) as evidenced by poor shoot and stunted growth, become discoloured and die.

Waterlogging and deoxygenation also results in a series of undesirable chemical and biochemical reduction reactions, the by-products of which are toxic to roots. Plant available nitrate-nitrogen ( $\text{NO}_3^-$ ) is reduced by denitrification to nitrite ( $\text{NO}_2^-$ ) and nitrous oxide ( $\text{N}_2\text{O}$ ), a potent greenhouse gas, and plant-available sulphate-sulphur ( $\text{SO}_4^{2-}$ ) is reduced to sulphide, including hydrogen sulphide ( $\text{H}_2\text{S}$ ), ferrous sulphide ( $\text{FeS}$ ) and zinc sulphide ( $\text{ZnS}$ ). Iron is reduced to soluble ferrous ( $\text{Fe}^{2+}$ ) ions, and Mn to manganous ( $\text{Mn}^{2+}$ ) ions. Apart from the toxic products produced, the result is a reduction in the amount of plant-available N and S. Anaerobic respiration of micro-organisms also produces carbon dioxide and methane (also greenhouse gases), hydrogen gas, ethanol, acetaldehyde and ethylene, all of which inhibit root growth when accumulated in the soil. Unlike aerobic respiration, anaerobic respiration releases insufficient energy in the form of adenosine triphosphate (ATP) and adenylate energy charge (AEC) for microbial and root/shoot growth.

The tolerance of the root system to surface ponding and waterlogging is dependent on a number of factors, including the time of year and the type of crop. Tolerance of waterlogging is also dependent on: soil and air temperatures; soil type; the condition of the soil; fluctuating water tables; and the rate of onset and severity of anaerobiosis (or anoxia), a factor governed by the initial soil oxygen content and oxygen consumption rate. Prolonged surface ponding makes the soil more susceptible to damage under wheel traffic, so reducing vehicle access. As a consequence, waterlogging can delay ground preparation and sowing dates significantly. Sowing can further be delayed because the seed bed is below the crop-specific critical temperature. Increases in the temperature of saturated soils can be delayed as long as water is evaporating.

### *Procedure:*

- Assess the degree of surface ponding based on your observation or general recollection of the time ponded water took to disappear after a wet period during the spring, and compare with the class limits in Table 4.



## How to score surface ponding (due to soil saturation)

**Good score** (2 points): There is no surface ponding of water after 1 day following heavy rainfall on soils that were at or near saturation.

**Moderate score** (1 point): There is moderate surface ponding of water after 2 to 4 days following heavy rainfall on soils that were at or near saturation.

**Poor score** (0 points): There is significant surface ponding of water up to 5 days following heavy rainfall on soils that were at or near saturation.



## 9. Surface crusting and surface cover

### *Relevance and importance:*

Surface crusting reduces infiltration of water and water storage in the soil and increases runoff. Surface crusting also reduces aeration, causing anaerobic conditions, and prolongs water retention near the surface, which can hamper access by machinery for months. Crusting is most pronounced in fine-textured, poorly structured soils with a low aggregate stability and a dispersive clay mineralogy.

Surface cover after harvesting and prior to canopy closure of the next crop helps to prevent crusting by minimizing the dispersion of the soil surface by rain or irrigation. It also helps to reduce crusting by intercepting the large rain droplets before they can strike and compact the soil surface. Vegetative cover and its root system return organic matter to the soil and promote soil life, including earthworm numbers and activity. The physical action of the roots and soil fauna and the glues they produce promote the development of soil structure, soil aeration and drainage and help to break up surface crusting. As a result, infiltration rates and the movement of water through the soil increase, decreasing runoff, soil erosion and the risk of flash flooding. Surface cover also reduces soil erosion by intercepting high impact raindrops, minimizing rain-splash and saltation. It further serves to act as a sponge, retaining rainwater long enough for it to infiltrate into the soil. Moreover, the root system reduces soil erosion by stabilizing the soil surface, holding the soil in place during heavy rainfall events. As a result, water quality downstream is improved with a lower sediment loading, nutrient and coliform content. The adoption of conservation tillage can reduce soil erosion by up to 90 percent and water runoff by up to 40 percent. The surface needs to have at least 70 percent cover in order to give good protection, while  $\leq 30$  percent cover provides poor protection. Surface cover also reduces the risk of wind erosion markedly.

### *Procedure:*

- Observe the degree of surface crusting and surface cover and compare Plate 12 and the criteria given. Surface crusting is assessed after wet spells followed by a period of drying, and before cultivation.

## How to score soil crusting and surface cover

**Good conditions** (2 points): There is little to no surface crusting or the surface cover is over 70%.

**Moderate conditions** (1 point): Surface crusting is around 2 to 3 mm thick and contains soil cracking, or the surface cover is between 30 and 70%.

**Poor conditions** (0 points): Surface crusting is over 5 mm thick and seems to be continuous with no soil cracking, or the surface cover is below 30%.



### GOOD CONDITION VS = 2

LITTLE OR NO SURFACE CRUSTING IS PRESENT;  
OR SURFACE COVER IS  $\geq 70\%$ .

### MODERATE CONDITION VS = 1

SURFACE CRUSTING IS 2-3 MM THICK AND IS  
BROKEN BY SIGNIFICANT CRACKING; OR  
SURFACE COVER IS  $> 30\%$  AND  $< 70\%$ .

### POOR CONDITION VS = 0

SURFACE CRUSTING IS  $> 5$  MM THICK AND  
IS VIRTUALLY CONTINUOUS WITH LITTLE  
CRACKING; OR SURFACE COVER IS  $\leq 30\%$ .

## 10. Soil erosion

### *Relevance and importance:*

Soil erosion reduces the productive potential of soils through nutrient losses, loss of organic matter, reduced potential rooting depth, and lower available-water-holding capacity. Soil erosion can also have significant off-site effects, including reduced water quality through increased sediment nutrient and coliform loading in streams and rivers. Overcultivation can cause considerable soil degradation associated with the loss of soil organic matter and soil structure. It can also develop surface crusting, tillage pans, and decrease infiltration and permeability of water through the soil profile (causing increased surface runoff). If the soil surface is left unprotected on sloping ground, large quantities of soil can be water eroded by gullying, rilling and sheet wash. The cost of restoration, often requiring heavy machinery, can be prohibitively expensive.

The water erodibility of soil on sloping ground is governed by a number of factors including:

- the percentage of vegetative cover on the soil surface;
- the amount and intensity of rainfall;
- the soil infiltration rate and permeability of water through the soil;
- the slope and the nature of the underlying subsoil strata and bedrock.

The loss of organic matter and soil structure as a direct result of overcultivation can also lead to significant soil loss by wind erosion of exposed ground.

### *Procedure:*

- Assess the degree of soil erosion based on current visual evidence and on your knowledge of what the site looked like in the past relative to Plate 13.

### **How to score soil erosion**

**Good condition** (2 points): There is little to no water erosion. The topsoil depths in the footslope areas are over 150 mm deeper than on the crest. Wind erosion is not an issue and only small dust plumes can be seen after using a cultivator on a windy day. Most of the wind-eroded soil is contained within the field.

**Moderate condition** (1 point): Water erosion is a moderate concern with a significant amount of rilling and sheet erosion. The topsoil depths in the footslope areas are 150 to 300 mm greater than on the crests. The sediment input into drains and streams due to erosion can be significant. Wind erosion is of moderate concern where significant dust plumes can be seen after using a cultivator on a windy day. Most of the wind-eroded soil is blown off the field but is still contained within the farm.

**Poor conditions** (0 points): Water erosion is a major issue and causes severe gullying, rilling and sheet erosion. The topsoil depths in footslope areas are more than 300 mm greater than on the crest. The sediment input into drains and streams due to erosion can be significantly high. Wind erosion is also a major issue, with large dust clouds when using a cultivator on a windy day. A significant amount of soil blown away can be lost from the field and deposited off-farm.



**GOOD CONDITION VS = 2**

LITTLE OR NO WATER EROSION. TOPSOIL DEPTHS IN THE FOOTSLOPE AREAS ARE <150 MM DEEPER THAN ON THE CREST. WIND EROSION IS NOT A CONCERN; ONLY SMALL DUST PLUMES EMANATE FROM THE CULTIVATOR ON A WINDY DAY. MOST WIND-ERODED MATERIAL IS CONTAINED IN THE FIELD.



**MODERATE CONDITION VS = 1**

WATER EROSION IS A MODERATE CONCERN WITH A SIGNIFI CANT AMOUNT OF RILLING AND SHEET EROSION. TOPSOIL DEPTHS IN THE FOOTSLOPE AREAS ARE 150-300 MM GREATER THAN ON CRESTS, AND SEDIMENT INPUT INTO DRAINS/STREAMS MAY BE SIGNIFI CANT. WIND EROSION IS OF MODERATE CONCERN WHERE SIGNIFI CANT DUST PLUMES CAN EMANATE FROM THE CULTIVATOR ON WINDY DAYS. A CONSIDERABLE AMOUNT OF MATERIAL IS BLOWN OFF THE FI ELD BUT IS CONTAINED WITHIN THE FARM.



**POOR CONDITION VS = 0**

WATER EROSION IS A MAJOR CONCERN WITH SEVERE GULLING, RILLING AND SHEET EROSION OCCURRING. TOPSOILS IN FOOTSLOPE AREAS ARE MORE THAN 300 MM DEEPER THAN ON THE CRESTS, AND SEDIMENT INPUT INTO DRAINS/ STREAMS MAY BE HIGH.WIND EROSION IS A MAJOR CONCERN. LARGE DUST CLOUDS CAN OCCUR WHEN CULTIVATING ON WINDY DAYS. A SUBSTANTIAL AMOUNT OF TOPSOIL CAN BE LOST FROM THE FI ELD AND DEPOSITED ELSEWHERE IN THE DISTRICT.

# Annex II - How to use a microwave oven to dry your soil sample?

---

**Step 1.** Choose a clean microwave safe dish, clean it and weigh it.

**Step 2.** Transfer the sample to the dish and record the weight (this would be recorded as wet weight, before the drying process begins).

**Step 3.** Place the dish with the sample in the microwave and dry for 3 minutes under the defrosting setting of the microwave.

**Step 4.** After the 3 minutes, remove the dish with the sample and weigh it. Mix the soil and dry for an additional 1 minute using the same microwave setting as in step 3.

**Step 5.** Repeat step 4 until the weight of the sample no longer changes.

**Step 6.** Your soil is now dry and can be used for the methods that require an oven dried soil.



# References

---

**Blair, G., Lefroy, R. & Lisle, L.** 1995. Soil carbon fractions based on their degree of oxidation, and the development of a carbon management index for agricultural systems. *Australian Journal of Agricultural Research*, 46(7): 1459. <https://doi.org/10.1071/AR9951459>

**Blair, G., Lefroy, R., Whitbread, A., Blair, N. & Conteh, A.R.** 2001. The development of the KMnO<sub>4</sub> oxidation technique to determine labile carbon in soil and its use in a carbon management index. *Assessment Methods for Soil Carbon*: 323–337.

**Casanellas, J.P.** 2013. *Agenda de Campo de Suelos: Información de Suelos para la Agricultura y el Medio Ambiente*. España, Mundi-Prensa. (also available at <https://library.biblioboard.com/content/9b37f9e8-code-43a0-ad65-bcffffe03ca>).

**Doran, J.W., Stamatiadis, S.I. & Haberern, J.** 2002. Soil health as an indicator of sustainable management. *Agriculture, Ecosystems & Environment*, 88(2): 107–110. [https://doi.org/10.1016/S0167-8809\(01\)00250-X](https://doi.org/10.1016/S0167-8809(01)00250-X)

**FAO.** 2006. *Guidelines for soil description*. 4th ed edition. Rome, Food and Agriculture Organization of the United Nations. 97 pp.

**FAO.** Date. General Training – Soil Texture. Fisheries and Aquaculture Department [CD-ROM]. Rome.

**Hoover, C.M., ed.** 2008. *Field measurements for forest carbon monitoring: a landscape-scale approach*. New York, NY, Springer. 240 pp.

**JG, R., Estefan, G. & Rashid, A.** 2002. *Soil--Plant-Analysis Soil and Plant Analysis Laboratory Manual*

**Kalra, Y.P.** 1995. Determination of pH of Soils by Different Methods: Collaborative Study. *Journal of AOAC INTERNATIONAL*, 78(2): 310–324. <https://doi.org/10.1093/jaoac/78.2.310>

**Keith, H. & Wong, S.** 2006a. Measurement of soil CO<sub>2</sub> efflux using soda lime absorption: both quantitative and reliable. *Soil Biology and Biochemistry*, 38(5): 1121–1131. <https://doi.org/10.1016/j.soilbio.2005.09.012>



- Keith, H. & Wong, S.** 2006b. Measurement of soil CO<sub>2</sub> efflux using soda lime absorption: both quantitative and reliable. *Soil Biology and Biochemistry*, 38(5): 1121–1131. <https://doi.org/10.1016/j.soilbio.2005.09.012>
- Keuskamp, J.A., Dingemans, B.J.J., Lehtinen, T., Sarneel, J.M. & Hefting, M.M.** 2013. Tea Bag Index: a novel approach to collect uniform decomposition data across ecosystems. *Methods in Ecology and Evolution*, 4(11): 1070–1075. <https://doi.org/10.1111/2041-210X.12097>
- Klute, A. & Page, A.L., eds.** 1982. *Methods of soil analysis*. 2nd ed edition. Agronomy No. no. 9. Madison, Wis, American Society of Agronomy : Soil Science Society of America. 2 pp.
- Lal, R., ed.** 2001. *Assessment methods for soil carbon*. Advances in soil science. Boca Raton, Fla, Lewis Publishers. 676 pp.
- Manitoba Agriculture, Food and Rural Initiatives.** 2008. Soil Management Guide.
- McKenzie, N., Coughlan, K. & Cresswell, H.** 2002. *Soil physical measurement and interpretation for land evaluation*. Collingwood, Vic, CSIRO Pub. 379 pp.
- Rao Mylavaram, Jamin Bergeron, Nancy Wilkinson & E. Hanlon.** 2020. Soil pH and Electrical Conductivity: A County Extension Soil Laboratory Manual. EDIS, 2020(1). (also available at <https://journals.flvc.org/edis/article/view/116038>).
- Rodrigues de Lima, A.C. & Brussaard, L.** 2010. Earthworms as soil quality indicators: local and scientific knowledge in rice management systems. *ACTA ZOOLOGICA MEXICANA (N.S.)*, 26(2). <https://doi.org/10.21829/azm.2010.262881>
- Shepherd, G., Stagnari, F. Pisante., M & Benites, J.** 2008. *Visual Soil Assessment – Field guides for annual crops*. FAO, Rome, Italy. 26 pp. (also available at <http://www.fao.org/3/i0007e/i0007e00.pdf>).
- United States Department of Agriculture (USDA).** 2001. *Soil Quality Test Kit Guide* [online]. Washington, DC. [Cited 21 February 2020]. [https://www.nrcs.usda.gov/Internet/FSE\\_DOCUMENTS/nrcs142p2\\_050956.pdf](https://www.nrcs.usda.gov/Internet/FSE_DOCUMENTS/nrcs142p2_050956.pdf)
- Weil, R., Stine, M., Gruver, J. & Samson-Liebig, S.** 2003. Estimating active carbon for soil quality assessment: A simplified method for laboratory and field use. *American Journal of Alternative Agriculture*, 18: 3–17. <https://doi.org/10.1079/AJAA200228>

Notes





The Global Soil Partnership (GSP) is a globally recognized mechanism established in 2012. Our mission is to position soils in the Global Agenda through collective action. Our key objectives are to promote Sustainable Soil Management (SSM) and improve soil governance to guarantee healthy and productive soils, and support the provision of essential ecosystem services towards food security and improved nutrition, climate change adaptation and mitigation, and sustainable development.

Thanks to the financial support of



**European  
Commission**

ISBN 978-92-5-131195-0



9 789251 311950

CA2796EN/1/05.20