

Nest Boxes

THEIR VALUE & ROLE IN AGRICULTURAL LANDSCAPES



Installing a nest box

Why install nest boxes?

- Mammals such as sugar gliders, squirrel gliders and phascogales need multiple hollows for shelter, nesting and breeding within their home range area of around 3 ha
- The clearing and loss of native vegetation, including mature trees with hollows, means there are often not enough natural hollows to support populations of these animals
- Natural hollows can take over 100 years to form, and revegetated areas often have few mature trees
- Nest boxes can provide animals a means of survival until sufficient natural hollows develop.

Where to install nest boxes

Choose an area:

- In a low-lying location, ideally in or near a gully, with fertile soils
- Of remnant or regenerated box gum woodland (especially yellow box)
- That is easily accessible for you to undertake ongoing monitoring and maintenance
- With some large hollow bearing trees, so the nest boxes can supplement existing habitat
- Within 30-50 m of other areas of vegetation, so the gliders can move between areas
- With a range of trees and shrubs to meet their feeding needs. Gliders particularly need access to nectar and plant exudates (eg sap from eucalypts and large wattles) during winter, when insects are scarce.

Choose 2 or 3 trees per hectare to attach your nest boxes. Choose trees that:

- Are box gums or stringybarks, as gliders climb best on rough bark. Don't choose ironbarks, as the bark is too thick to attach the box to the tree
- Have a dense crown, to keep the box cool on hot days
- Have branches to shield the box from predators, such as owls, and provide shelter from cold winds.

"Nest boxes can provide animals a means of survival until natural hollows develop"

How to install nest boxes

- Select a position in the tree where the box will have some protection from the elements (wind, rain and direct sun). The entrance should face away from prevailing winds
- Install the nest box around 2-5 m from the ground, to make it safe from predators but low enough for you to safely inspect and maintain
- Use a ladder to secure the nest box, and make sure someone is with you to support the ladder and provide assistance
- Ensure that the ground below the nest box is clear of any obstacles for the secure placement of your ladder for installation and monitoring purposes
- Attach the box to the tree using galvanised coach screws, through strap braces.

Monitoring of nest boxes

Monitoring is important to record the usage of your nest boxes by native wildlife.

- Wait at least 3 months between inspections. Ideally, aim to inspect each nest box twice a year
- Check the box for chewing or scratch marks, which may indicate usage
- A brief visual inspection should not harm a resident glider.

Maintenance of nest boxes

Nest boxes should be maintained to prolong their life, and keep them in good condition to encourage native animals to use them.

Maintenance can be conducted when monitoring boxes. If native animals are using the box when you check it, leave any repairs to a later time (unless critical).

- Boxes may begin to split along the grain or form gaps between the joins. Use an outdoor wood filler or construction glue to repair the box if necessary
- Check the points where the box is attached to the tree, to ensure it remains secure and is not causing damage to the tree. If necessary, remove the screws and reattach the straps more loosely
- If bees have invaded acquire an apiarist (bee-keeper) to remove the hive. Alternatively, place a pest strip in the box (be sure to do this early morning/evening on a cold day, when the bees are not active)
- Remove any cob webs, spiders and ants
- There is no need to clean the box out. Sugar gliders keep their nests fairly clean and, while squirrel gliders and phascogales will defecate in their box, this is normal and should not be removed.



Installing a nest box



A recently installed nest box

This Fact Sheet is one of a series produced through the Murrumbidgee Landcare project "Cross Property Planning to Balance Production and Conservation". This project was assisted with funding from the NSW Environmental Trust's "Community Bush Regeneration" program, and the Australian Government.



MURRUMBIDGEE
Landcare
INCORPORATED



Australian Government



Cross Property Planning project: Nest Box program

Nest boxes for squirrel gliders, sugar gliders and brush-tailed phascogales

Material requirements per box

Plywood or rough sawn pine, 25 mm thick (discard any really bad knots):

- 1 front wall: 200 x 420 mm
- 1 back wall: 200 x 450 mm
- 2 side walls: 200 x 420/450 mm (see diagram)
- 1 floor: 200 x 155 mm
- 1 roof: 200 x 310 mm

Flat galvanised sheet:

- 2 mounting plates: 80/25 x 80/25 mm (see diagram)

Hardware:

- Wire catch for roof
- 70 mm hinge plus screws
- Approximately 25 galvanised screws: 2.8 mm x 65 mm
- Coach bolts and nuts to bolt mounting plates to tree: 1.5 x 5/16 in

Contact

Nicole Maher: 0438 452 814, or nmaher@mli.org.au; or

Jacinta Christie: 0431 953 778, or jchristie@mli.org.au.

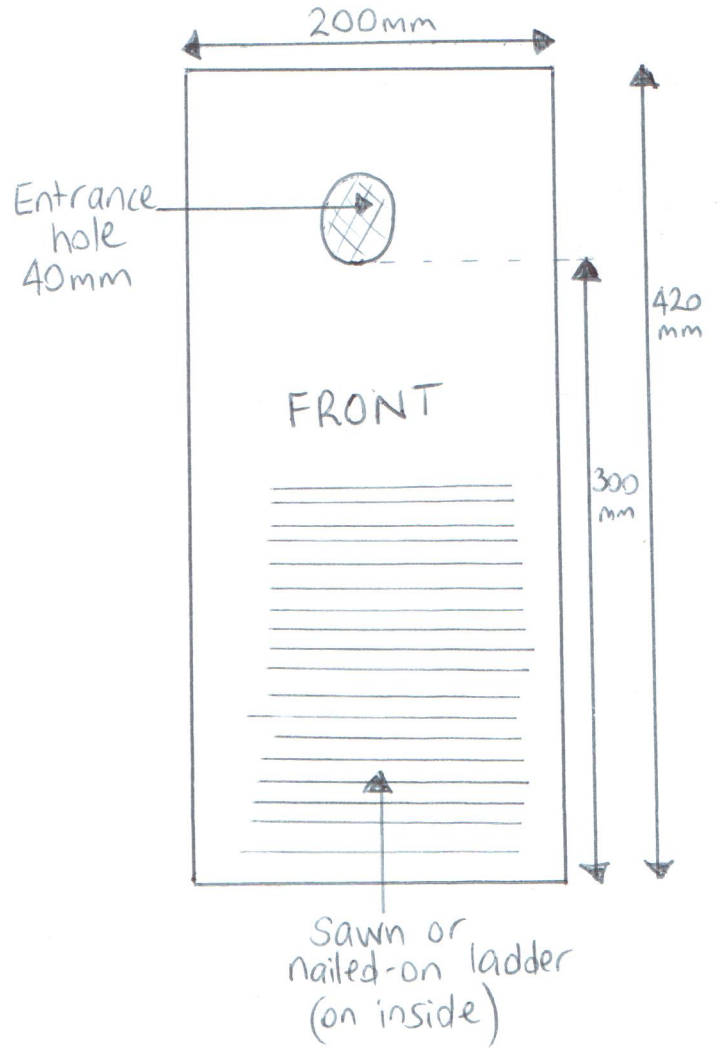
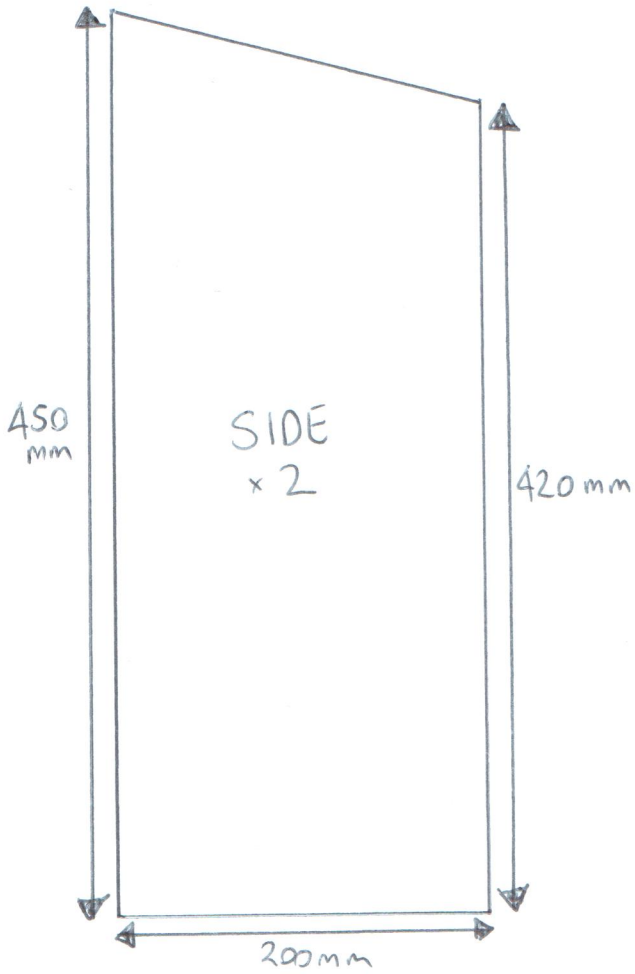

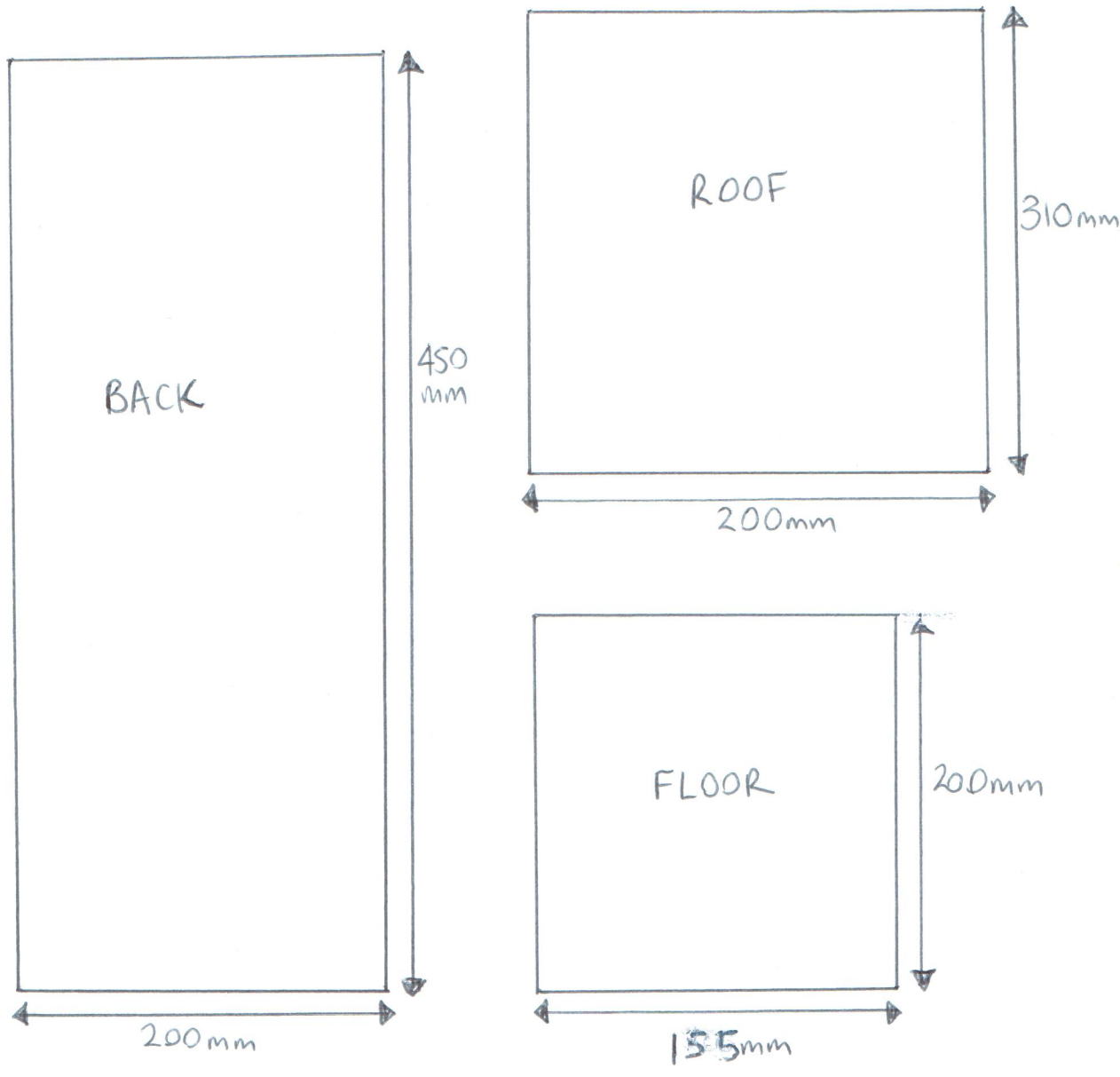

Not to scale

Nest Box Mounting Brackets.
one bent for LHS, one bent for RHS.

